

Hydrogen – Future or no Future?

Last edition: 7/4/2022

by André Duarte B. L. Ferreira

This work is in draft stage.

*I don't claim to have made everything here (but **mostly** it was me, exception to this are images and tables). Because this is for personal use only, for learning, and **not** for sale, and to save time, there are several original sources I didn't reference, when/if applicable.*

Purpose

Hydrogen continues to be mentioned as a viable alternative to fossil fuels for transportation, home use and as a viable storable energy source. However much as been said, not as much as been accomplished as the predictions would lead one to believe. The point of this document is to provide an overview about

To do

1. Continue elaborating this document.
2. Resolve questions (yellow).

Abbreviations and Symbols

Abv.	Description
AIT	Auto Ignition Temperature
FC	Fuel Cell
FL	Flammability Limit
LH ₂	Liquid Hydrogen
GH ₂	Gaseous Hydrogen
HFC	Hydrogen Fuel Cell
ICE	Internal Combustion Engine
MIE	Minimum Ignition Energy
NTP	Normal Temperature and Pressure ^{*1}
STP	Standard Temperature and Pressure ^{*2}

^{*2} 273 K (0 °C), 101325 Pa (1 atm).

Symbol	Description
ρ	Mass density
η	Efficiency
#	Chapter finished

^{*1} 293 K (20 °C), 101325 Pa (1 atm).

1. Properties

1.1. General

Hydrogen is the most common element in the universe – it's estimated that 75% of all the universe's mass consists of hydrogen (**Table 1**). It is also the lightest element with a density of 0.09 kg/m³ (STP). It is odorless (can't be smelled), colorless (can't be seen), tasteless (can't be tasted) and non-toxic (no ill effects if inhaled in small quantities). Because it's so light it has escaped Earth's atmosphere, as Earth's gravity is not strong enough to hold it here, so if we want it we need to produce it.

Giant molecular cloud formations, consisting almost entirely of hydrogen, are the most massive objects within galaxies. Gravity eventually causes the hydrogen to compress until it fuses into heavier elements.

Both anglo-saxon name 'hydrogen' (coming from the greek words 'hydor' = water and 'genes' = generate) and roman 'waterstof' make reference to the water producing properties.

Table 1 Current estimation of element abundance (% mass) in the universe (1). Note: including the element being part of other molecules, i.e. not only in its pure form.

Rank	Element	(% mass)
1	Hydrogen	75
2	Helium	23
3	Oxygen	1
4	Carbon	0.5
5	Neon	0.13

Table 2 Properties of hydrogen compared to Diesel (2).

Name	Hydrogen	Diesel
Formula	H ₂	C _n H _{1.8n}
Density (kg/m ³)	0.09	833 to 881
Auto ignition temperature (°C)	1131	806
Lower heating value (MJ/kg)	120	42.5
Molecular weight (g/mol)	2.02	170
Flammability limits in air (vol %)	4 to 75	0.7 to 5
Flame velocity (m/s)	2.65 to 3.25	0.3
Melting point (°C) (atm pressure)	-259	-30 to -18
Boiling point (°C) (atm pressure)	-252	180 to 360
Octane number	130	30
Min. ignition energy (mJ)	0.02	0.24

Explosive concentration with air (%v)	4.1 - 75	1 < - 10
State at NTP	Gas	Liquid

There is a **critical temperature** above which a gas can no longer be liquefied, no matter how high the pressure. In the case of hydrogen the critical temperature is -239.96°C (33.19 K) (For water it's 374°C). If hydrogen is to be liquefied, its temperature must be below this point.

Similarly, once it reaches a sufficiently high pressure, a gas can no longer be liquefied, even by lowering the temperature further. This pressure is known as the **critical pressure**, and for hydrogen it is 13.1 bar (for water 220 bar).

If we set a fluid at its critical temperature and critical pressure at the same time, that setup is the **critical point**. At the critical point of a substance the liquid and gas phase merge (**Fig. 1**).

The **triple point** or **three phase point** of a substance is the point in the phase diagram at which all three states of matter are in thermodynamic equilibrium; for hydrogen this point is at -259.19°C and 0.077 bar. The triple point is also the lowest point of the vapor-pressure curve. The vapor pressure curve indicates pressure-temperature combinations at which the gas and liquid phases of hydrogen are in equilibrium. To the left of the vapor-pressure curve hydrogen is liquid, to the right it is gaseous. To the right of and above the critical point, hydrogen becomes a **supercritical fluid**, which is neither gaseous nor liquid and has properties in-between the two.

This is important to know because near the critical point, a supercritical fluid deviates considerably from ideal gas behavior and small changes in pressure yield large changes in density. At temperatures much higher than the critical temperature fluids tend to be more gas like and may be close to ideal gas behavior.

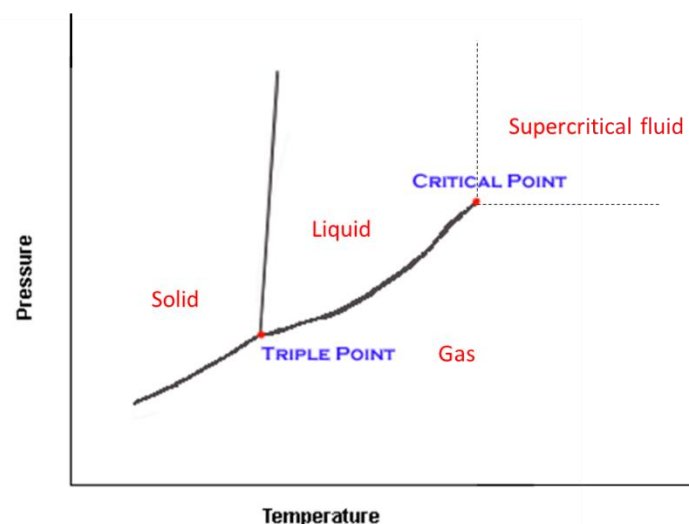

Fig. 1 Triple and critical point of a substance.

Compared with that of methane, the vapor-pressure curve of hydrogen is very steep and short – over a small temperature and pressure range. As a consequence, liquefaction takes place primarily by cooling and less so

by compression. By contrast, the compressed storage of hydrogen (at 350 or 700 bar) always takes place as a supercritical fluid.

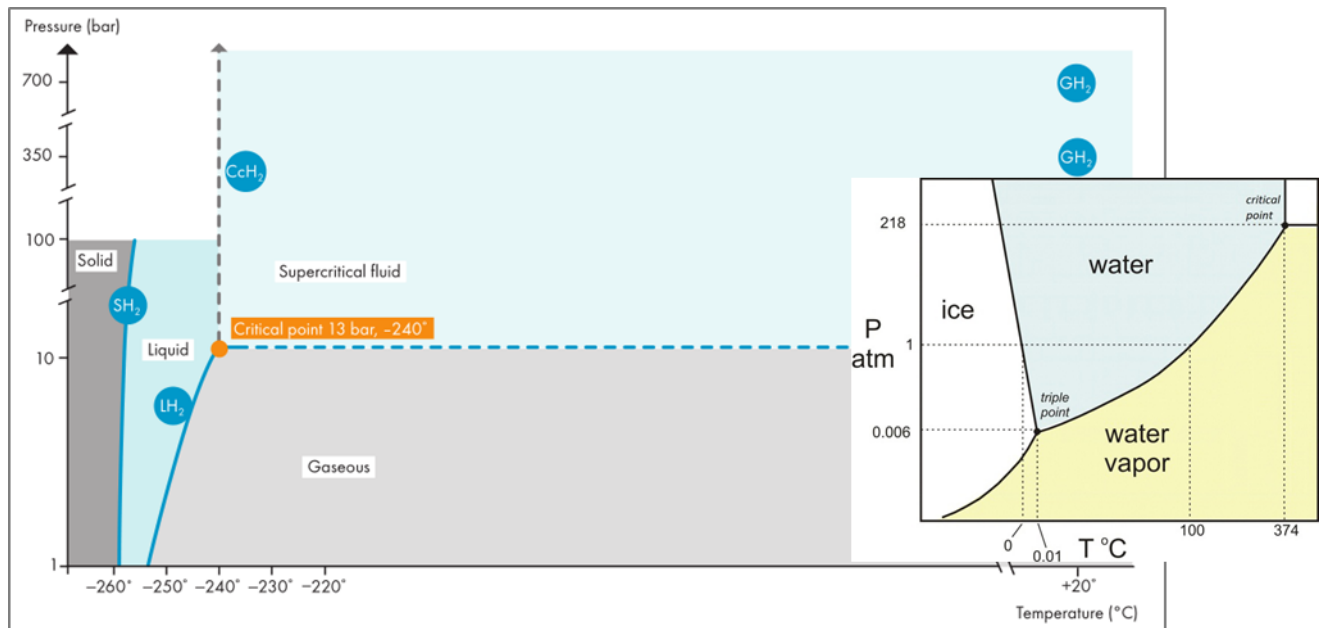

Fig. 2 Phase diagram of hydrogen, and of water for comparison.

Hydrogen has 3 **isotopes**: protium, deuterium and tritium whose difference is the increasing number of neutrons. Protium only consists of 1 proton and no neutrons, deuterium of 1 proton and 1 neutron and tritium, of one proton and 2 neutrons (**Fig. 3**). Depending on whether the protons of an H-H compound rotate in parallel or in opposite directions about their own axis (nuclear spin), the two modifications are known respectively as ortho-hydrogen and para-hydrogen. Ortho-hydrogen (o-H₂) has a higher energy content than para-hydrogen (p-H₂)

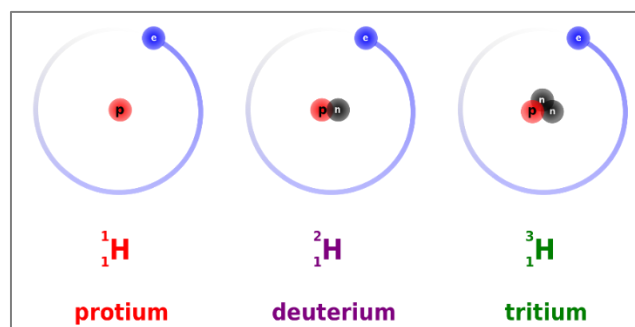

Fig. 3 Schematic representation of the 3 isotopes of hydrogen, protium, deuterium and tritium. (3)

Contrary to tritium, deuterium is stable and represents about 0.015% of all hydrogen.

References

- (1) nl.wikipedia.org/wiki/Deuterium
- (2) researchgate.net/figure/PROPERTIES-OF-DIESEL-AND-HYDROGEN-12-22_tbl1_279192597
- (3) wolframalpha.com/input/?i=elements+universe+abundance

1.2. Density comparisons

Specific energy density (J/kg) of Hydrogen is higher than most gases but volumetric energy density (J/L) is lower. (Fig. 4). While 1L of gasoline at **Normal Temperature and Pressure (NTP)** (20 °C, 1 atm) contains 31 MJ, 1L of hydrogen in the same conditions only contains 0.11 MJ. That’s ~280 times more energy per volume. Even in liquid form, gasoline has ~4 times more energy per volume than hydrogen. **There is actually more hydrogen in a liter of gasoline (116 g) than in a liter of liquid hydrogen (76 g).** This alone exposes the need for hydrogen to be stored at high pressure / low temperature if we want any sort of usable volumetric energy density.¹

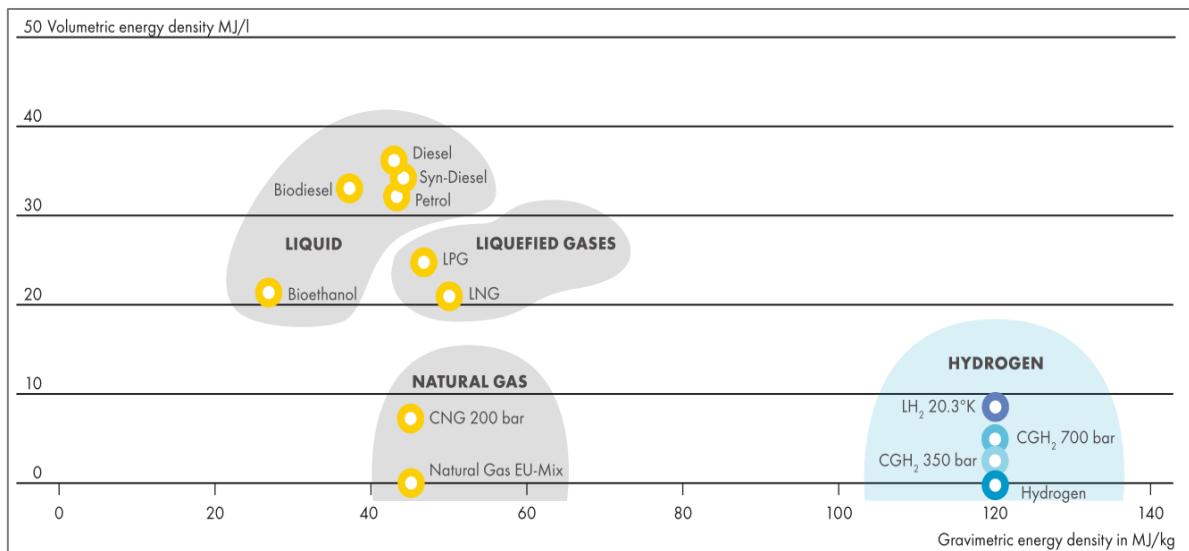

	Specific energy density (MJ/kg)	Density (kg/m ³)	Volumetric energy density (MJ/L)
Hydrogen	120	0.09	0.011
Methane	50	0.65	0.032
Propane	50	1.8	0.09
Butane	28	2.5	0.07
Gasoline	45	700	31
Li-ion	1	400	0.4

Fig. 4 Top) Energy density of fuels (1). Bottom) Some properties of common fuels and energy carriers @ NTP.

References:

- (1) Shell H₂ Study

¹ As a side note, Uranium and Plutonium-239 have an energy density of 80 000 000 MJ/kg, so almost 600 thousand times more energy density than liquid H₂ and 2 million times more than gasoline. We don’t currently use the Uranium in this state, so the actual density of usable uranium after all efficiency losses are accounted for are less, but this gives still an idea for the end-game potential of nuclear energy sources, if ever feasible.

2. Production

2.1. Introduction

Currently ~95% of hydrogen worldwide is produced from fossil fuels such as natural gas² and coal. The end products are usually hydrogen and carbon monoxide. The remaining 5% of hydrogen production is from electrolysis of water or biomass gasification. For this reason, currently using hydrogen is not as clean as it is thought to be, as it is just a by-product of fossil fuel processing and results in considerable carbon emissions, usually as CO₂.

Depending on the method of production of hydrogen, from less to more environmentally friendly we have different names for hydrogen:

Grey hydrogen is the name we give to hydrogen obtained from fossil fuels.

Blue hydrogen, is named for hydrogen also obtained from fossil fuels but which carbon emissions are captured and stored to be reused, in a process that we usually call **Carbon Capture and Storage (CCS)**.

Green hydrogen is hydrogen produced using only renewable energy, typically through the process of electrolysis. Have in mind that after production it also needs to be stored (pressurized). Compressing a gas requires energy which may not come from renewable sources...

Blue hydrogen might pose a good bridge for the switch between grey and green hydrogen as the cost of green hydrogen becomes competitive with that of grey. The captured CO₂ can be sold³. As fossil fuel prices increase, so will the price of CO₂ as much of it is a by-product of fuel production. This increase in price of CO₂ can make blue hydrogen a cheaper alternative than grey, until green catches up to the two of them and becomes the de-facto choice.

² Natural gas is the name given to gas extracted from the depths of earth and which consists of a mixture of gases namely Methane (>85%), Ethane (3-8%), Propane (1-2%), Butane, Pentane, Carbon Dioxide, among others.

³ CO₂ in solid and liquid form is used for cooling systems as well as an inert gas in chemical reactions. It's also used in many industrial applications such as in the manufacturing of electronics, fire extinguishers, for coatings, adhesives, concrete, among many others.

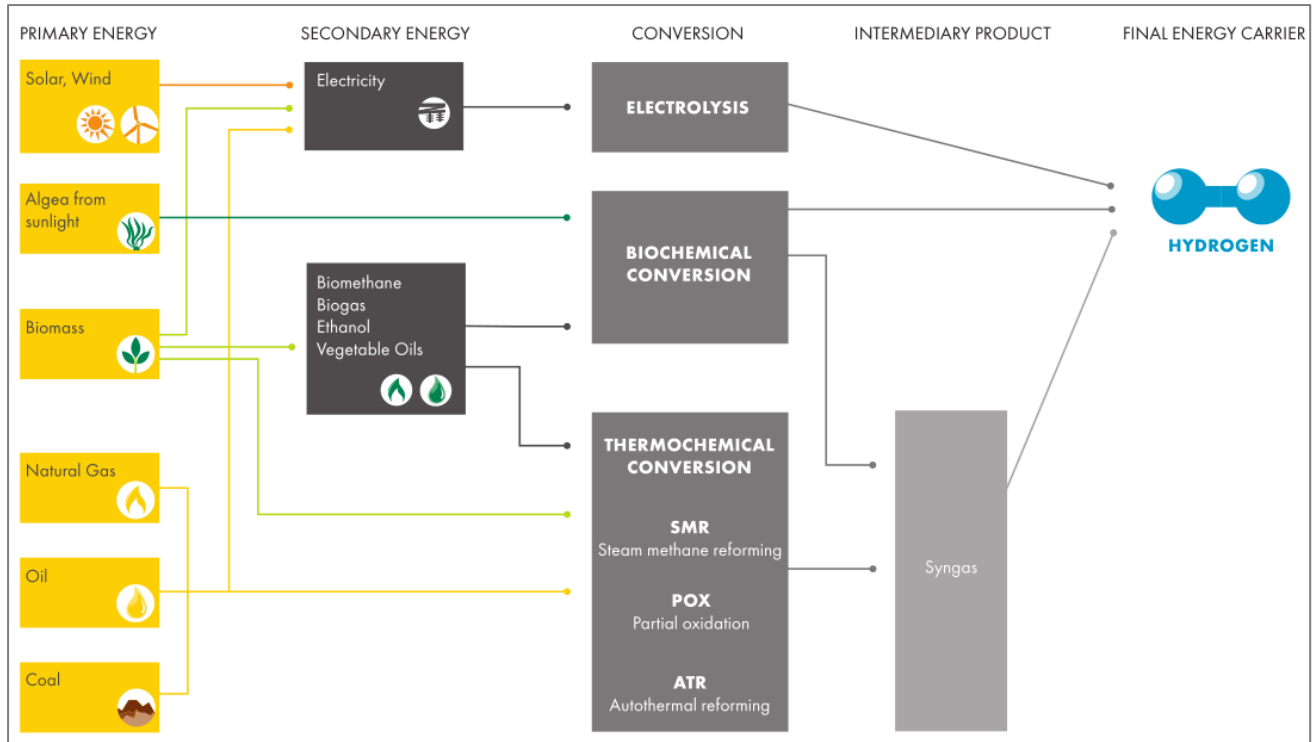

Fig. 5 Processes for producing hydrogen.

Table 3 Comparison of costs of different hydrogen production methods (2). SMR = Steam Methane Reforming, CG = Coal gasification, ATR = auto thermal reforming.

Process	Energy source	Feedstock	Capital cost (M\$)	Hydrogen cost [\$/kg]
SMR with CCS	Standard fossil fuels	Natural Gas	226.4	2.27
SMR without CCS	Standard fossil fuels	Natural Gas	180.7	2.08
CG with CCS	Standard fossil fuels	Coal	545.6	1.63
CG without CCS	Standard fossil fuels	Coal	435.9	1.34
ATR of methane with CCS	Standard fossil fuels	Natural Gas	183.8 ^a	1.48
Methane Pyrolysis	Internally generated steam	Natural Gas	-	1.59–1.70
Biomass Pyrolysis	Internally generated steam	Woody Biomass	53.4–3.1 ^b	1.25–2.20
Biomass Gasification	Internally generated steam	Woody Biomass	149.3–6.4 ^c	1.77–2.05
Direct Bio-photolysis	Solar	Water + Algae	50 \$/m ²	2.13
Indirect Bio-photolysis	Solar	Water + Algae	135 \$/m ²	1.42
Dark Fermentation	-	Organic Biomass	-	2.57
Photo-Fermentation	Solar	Organic Biomass	-	2.83
Solar PV Electrolysis	Solar	Water	12–54.5	5.78–23.27
Solar Thermal Electrolysis	Solar	Water	421–22.1 ^d	5.10–10.49
Wind Electrolysis	Wind	Water	504.8–499.6 ^e	5.89–6.03
Nuclear Electrolysis	Nuclear	Water	-	4.15–7.00
Nuclear Thermolysis	Nuclear	Water	39.6–2107.6 ^f	2.17–2.63
Solar Thermolysis	Solar	Water	5.7–16 ^g	7.98–8.40
Photo-electrolysis	Solar	Water	-	10.36

As of 2013 centralized gas reforming was the cheapest option to obtain hydrogen from (1.8€/kg H₂), and decentralized electrolysis the most expensive (up to 12 €/kg H₂) (Fig. 6).

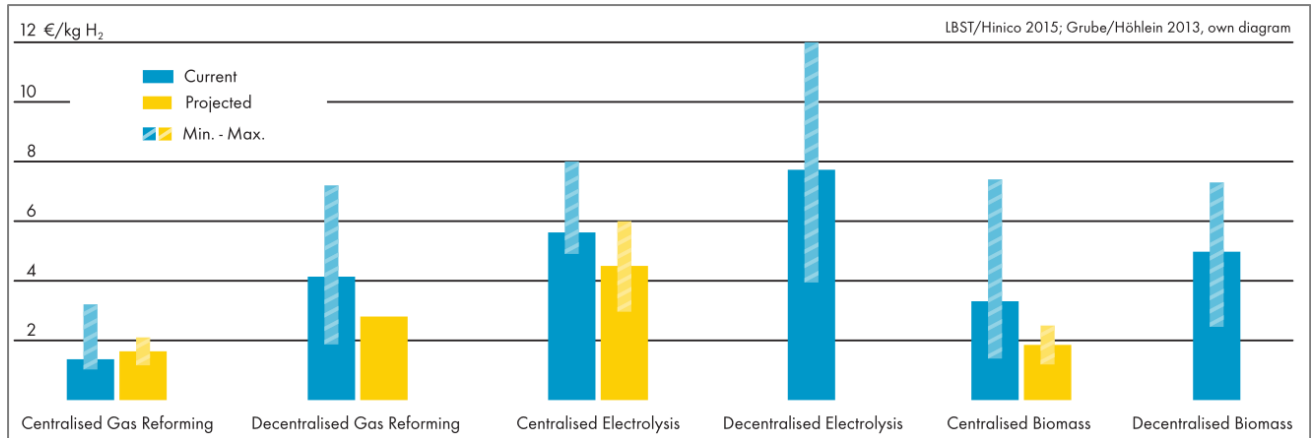

Fig. 6 Hydrogen production costs for main production methods (1).

The size and location of the production unit will depend on the demand and supply strategy from that user. Hydrogen can be generated from large specialized power plants or decentralized in small plants directly at the point of use or in large and subsequently transported by pipeline or lorry to the dispensing stations.

References

- (1) Ludwig-Bölkow Systemtechnik (LBST), Hinico S.A., Study on hydrogen from renewable resources in the EU (GHyP), München, Brüssel 2015
- (2) P. Nikolaidis, A. Poullikkas / Renewable and Sustainable Energy Reviews 67 (2017) 597–611

2.2. Thermochemical Processes

Hydrogen can be produced in several ways with different raw materials and also using different technology solutions. However, the cheapest solution nowadays remains the least eco-friendly, reforming of fossil fuels.

Reforming of fossil hydrocarbons is by far the most widespread method of hydrogen production. Reforming is the conversion of hydrocarbons and alcohols⁴ by chemical processes into hydrogen, giving rise to the by-products water (vapor), carbon monoxide and carbon dioxide.

The reaction takes place at high temperatures (between approx. 700°C and 900°C) and the conversion is assisted by a catalyst. In addition to the raw material, reforming requires an oxidant, which supplies the necessary oxygen.

Based on the oxidant and the direction of heat transfer (or its inexistence), three basic methods can be identified:

1. **Steam Reforming:** Pure water vapor is used as the oxidant. The reaction requires the introduction of heat (endothermic).
2. **Partial Oxidation:** Oxygen or air is used in this method. The process releases heat (exothermic).
3. **Autothermal Reforming:** This process is a combination of steam reforming and partial oxidation and operates with a mixture of air and water vapor. The ratio of the two oxidants is adjusted so that no heat needs to be introduced or discharged (isothermal).

⁴ A hydrocarbon is a molecule consisting only of hydrogen and carbon, so C_xH_y. An alcohol is a molecule with the generic formula of C_nH_{2n+1}OH.

Of these the most used one is steam reforming and the most commonly used fuel used in it is methane. This process consists of two steps:

1. Steam-methane reforming reaction – steam at 700°C - 1000°C reacts with methane at 3 bar – 25 bar in the presence of a catalyst to form water vapor, hydrogen, monoxide carbon and a small amount of carbon dioxide. This composition forms what is called **syngas** or **synthesis gas**.

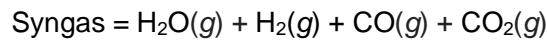

2. Water-gas shift reaction – this monoxide carbon is then made to react with steam resulting in even more hydrogen and a less polluting CO₂ product.



2.3. Electrolysis

The biggest source of hydrogen atoms is actually in one of the safest and most available substances: water. If hydrogen could efficiently be extracted from water, its price would plummet and the number of applications where it would be economically feasible to use it would skyrocket.

Hydrogen can be extracted from the water molecules in a process we call **electrolysis**. Electrolysis is a process where electrical energy (direct current) is used to create and maintain a chemical reaction. To the setup that makes this reaction possible we call **electrolyser**. The electrolyser consists of a DC power source, two electrodes and an electrolyte (ionic conductor). The voltage needed between the two electrodes to drive that chemical reaction is called **decomposition potential**. The word ‘decomposition’ comes from the fact that in electrolysis we are splitting – or decomposing – molecules. When we supply the decomposition potential to the electrodes an electric current passing from one electrode to another through water to decompose water into oxygen and hydrogen. For water, the decomposition potential is ~1.23V. This means that if we supply, for example, 1.2 V between the two electrodes no decomposition of water into H₂ and O₂ will occur.

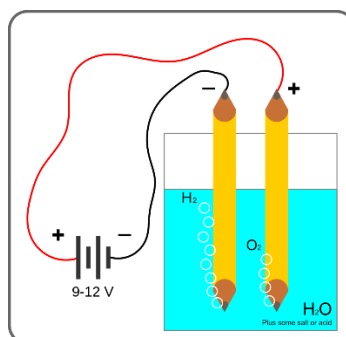
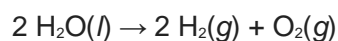

Fig. 7 Diagram explaining the basic setup needed to electrolyze water.

Efficiency of electrolysis is defined by the amount of electricity used to produce an amount of hydrogen. Currently, electrolysis efficiency runs around 60-80%, meaning 40-20% of it is wasted as heat/radiation, so not

used to produce hydrogen. A 100% efficient electrolyzer would consume 39.4 kWh/(kg H₂) or (142MJ). This means that we could combine oxygen and hydrogen and then split water cyclically indefinitely. This means that we currently need 1.2 – 1.7 J to split water from which hydrogen we will then be able to extract 1 J by combining it with oxygen again.

The efficiency is greatly increased through the addition of an **electrolyte**⁵ such as a salt, an acid or a base. For comparison distilled water has 1 million times less electrical conductivity than sea water. Electrolysis of distilled water requires then a much greater voltage.

There are currently 3 main electrolysis technologies to obtain hydrogen from water (these are similar to the corresponding fuel cell technology):

- 1) **Alkaline Electrolysis Cells** (AEC).
- 2) **Proton Exchange Membrane** (PEM).
- 3) **Solid Oxide Electrolysis Cells** (SOEC).

Their main way of working can be seen in **Fig. 8**. By far the most used is the PEM.

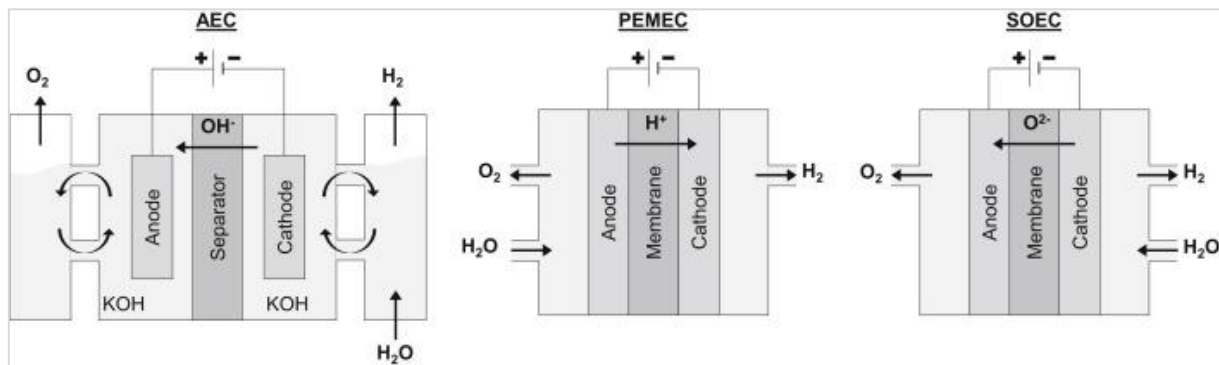

Fig. 8 Functional diagram of the 3 main electrolysis technologies.

⁵ An electrolyte is a substance that gets separated into ions when dissolved in a solvent. Salt (NaCl) is an electrolyte because when you dissolve it into water it separates into its ions of Na⁺ and Cl⁻. The existence of ions in a solution facilitates electric current because of the fact that there are charged particles where the electrons that constitute that current can get propelled to/from.

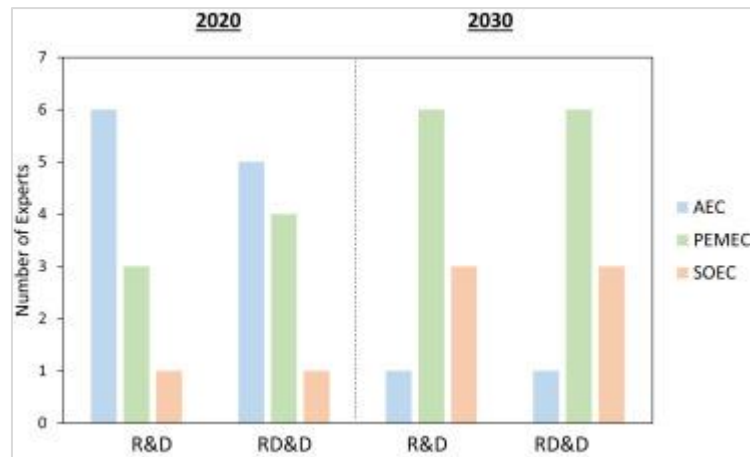

Fig. 9 Predicted technology suitability with and without production scale-up (RD&D and R&D)

Resources:

- (1) [sciencedirect.com/science/article/pii/S0360319917339435](https://www.sciencedirect.com/science/article/pii/S0360319917339435)

2.4. Other production methods

Biogenic production with or without the use of microorganisms, “thermochemical water splitting” and artificial photosynthesis, are at earlier stages of development but are other possible ways of producing hydrogen.

3. Purification

3.1. Introduction

The purification process takes place after hydrogen production as we do not get 100% pure hydrogen. There are always **contaminants**. Even in production processes such as water electrolysis, where pure or distilled water is used, a purification step is often necessary to obtain the desired purity.

Impurities or contaminants in fuel cells reduce working efficiency and longevity of the system (3). For example, air is the most practical and economical way to feed a fuel cell (for the oxygen). However it usually contains oxides (nitrogen, sulfur and carbon oxides). These contaminants not only reduce the FC’s longevity but also its power. This effect usually gets worse with increasing concentrations of contaminant (**Fig. 10**).

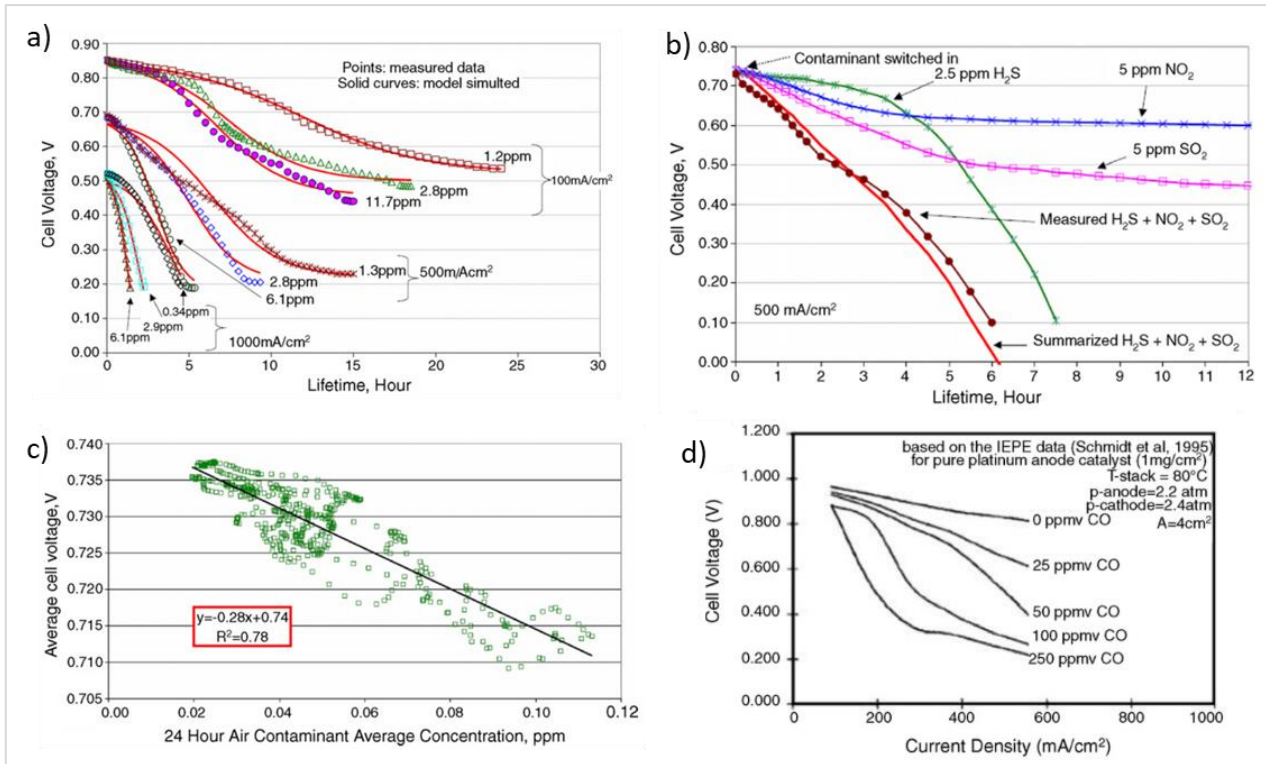

Fig. 10 a) Effect of H₂S contamination on cell performance and lifetime. **b)** Individual and combined effects of 5ppm NO₂ and 5ppm SO₂ in air and 2.5ppm H₂S in fuel on cell voltages and lifetime. **c)** Average cell voltage as a function of 24h average NO_x concentration. **d)** Effects of CO concentration on cell performance. (3)



Fig. 11 Example of what a hydrogen purification unit looks like (1).

Purity is defined by mass percentage as:

$$\text{Purity (\%)} = \frac{\text{mass of desired compound in impure sample}}{\text{total mass of sample}} (\%)$$

Note: it does not preclude impurities not tested for (e.g. Sodium, Lithium, Potassium, etc.)

A hydrogen FC can require the supplied hydrogen to have a purity of up to 99.9999%.

3.2. Adsorption/desorption processes

This technology is based on the binding of gas molecules to an adsorbent material. The impurities (adsorbates) are adsorbed over a porous solid, like a filter. The separation effect is based on differences in binding forces to the adsorbent material. Highly volatile components with low polarity, such as H_2 , are practically non-adsorbable as opposed to molecules like hydrocarbons, CO and H_2O . Indeed, these compounds that act as impurities can be adsorbed from a hydrogen rich stream and thus, a high purity hydrogen stream can be obtained.

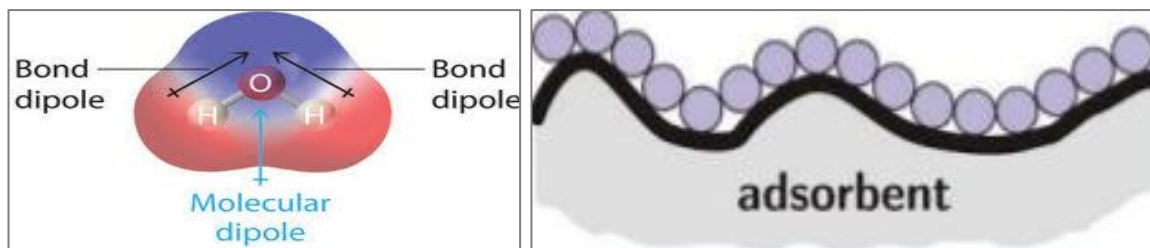

Fig. 12 Left) Polarity of an H_2O molecule. Right) Molecules adhering to the surface of an adsorbent material.

These processes are cyclic, that means when all adsorbent material is full of impurities, the adsorbent material will be cleaned. As a result of the cleaning process, the impurities on the adsorbent material are removed and thus the adsorbent material is regenerated. This process is called regeneration. After regeneration the cleaning of hydrogen flow starts again.

The adsorbent material solids most used in this kind of purification process are:

- Zeolites⁶
- Activated charcoal⁷
- Silica (SiO_2) gel.
- Alumina (Al_2O_3) gel.

Moreover, there are characteristics of the adsorbent materials that should be understood to design this kind of purification process:

- Contaminant–adsorbent affinity (only certain molecules with certain chemical characteristics are retained).
- Pore size (molecules with a certain size are trapped).
- etc.

All those characteristics have to be studied to choose the proper one. Through the combination of different adsorbent materials, several compounds can be eliminated.

⁶ Zeolites are microporous, aluminosilicate minerals (Al_2SiO_5) commonly used as commercial adsorbents and catalysts.

⁷ Activated charcoal is a form of carbon obtained from burning carbon rich materials such as wood, processed to have small, low-volume pores that increase the surface area available for adsorption or chemical reactions.

Two adsorber vessels working in parallel are required to provide continuous hydrogen supply. Whilst one is cleaning the hydrogen gas, the other one is regenerating. Once the purifying vessel saturates, gas flows are switched due to valves with interconnecting piping. Ten or more vessels operate simultaneously at different pressures and temperatures depending on the processes.

Depending on the regeneration process there are several types of purification systems, the most used are the following:

3.2.1. PSA (Pressure Swing Adsorption)

The PSA is the most commonly used adsorption/desorption process, and it follows four basic steps (**Fig. 13**):

1. Adsorption
2. Depressurization
3. Regeneration
4. Repressurization

The PSA process works at constant temperature and uses the effect of alternating pressure, in the range of 10 to 40 bar, to perform adsorption and desorption.

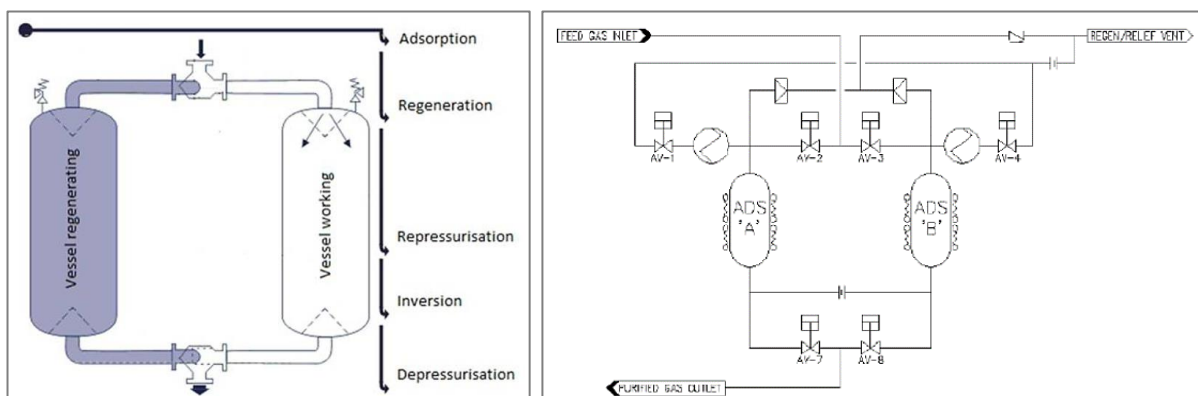

Fig. 13 PSA process block diagrams.

3.2.2. TSA (Temperature Swing Adsorption)

Contrary to PSA, in TSA temperature is made to vary. With increasing the vessel temperature, the impurities that are in the solid move towards the gas. It consists in 4 steps:

1. Feed
2. Rinse
3. Heating
4. Cooling

The last two are to regenerate the adsorbant.

3.2.3. PSA + TSA

Some purifiers use a combination of PSA + TSA system.

3.3. Selective reactors

The selective reaction, or the partial oxidation of impurities, allows the removal of trace contaminants, mainly CO and O₂. This system enables continuous operation.

In gas streams with CO and O₂ traces, CO removal has the priority over the oxygen elimination. For this purpose, mixtures of catalysts like ruthenium and copper with lanthanum or cerium-catalysts supported on alumina are used. The reaction is highly selective, as it mainly converts CO to CO₂ but not H₂ to H₂O. However, some hydrogen is used to remove oxygen when the process only shows oxygen traces, thanks to the presence of catalysts. Such processes are sensitive to the presence of sulphur, so it must be removed before beginning the process.

When water electrolysis is the source of the hydrogen, particle beds with a little platinum supported on alumina are mainly used to promote the oxygen removal reaction with the hydrogen reaction. As a result of this reaction, there is the reduction of O₂ content to levels of 3 – 10 parts per million (ppm). Also, the amount of hydrogen is reduced because of the trace amounts of hydrogen and so hydrogen loss is minimal.

Later, a purification stage for separating the H₂ from the other generated gases is needed. This stage is really important since it enables further separation with membranes or with the adsorption/desorption process.

3.4. Membranes

This purification system is mainly used for hydrogen production on a small-scale. This kind of purification employs membranes that are permeable to hydrogen but not to other substances such as CO₂, CO, H₂O, H₂S and CH₄. Usually additional steps are needed, depending on the membranes and hydrogen quality required. For instance, dense metal membranes reach high purity in only one step, whereas with polymer membranes intermediate compression and cooling stages are necessary.

One of the more important factors is the transfer area between the gas to be purified and the membrane. The temperature is another critical element, since hydrogen mobility through membranes is directly proportional to temperature. However, high temperatures can cause membrane breakage.

There are four types of membranes that are, or can be, used in industrial applications. The mechanisms that enable hydrogen purification change depending on each membrane type:

- Polymer membranes, diffusion through the polymer material – Polymer Membrane Diffusion.
- Porous membranes (ceramic materials, coal or metals), via gas size separation.
- Dense metal membranes, hydrogen diffusion and dissolution through the metal.
- Ion-conducting membranes, hydrogen selective diffusion.

Palladium is very commonly used as a membrane because hydrogen is the only atom capable of diffusing across a palladium membrane. The diffusion is driven by a pressure difference and this transference occurs at approx. 400 C. To prevent impurity buildup, a small amount of hydrogen is used to vent along with the impurities in the impurities outlet.

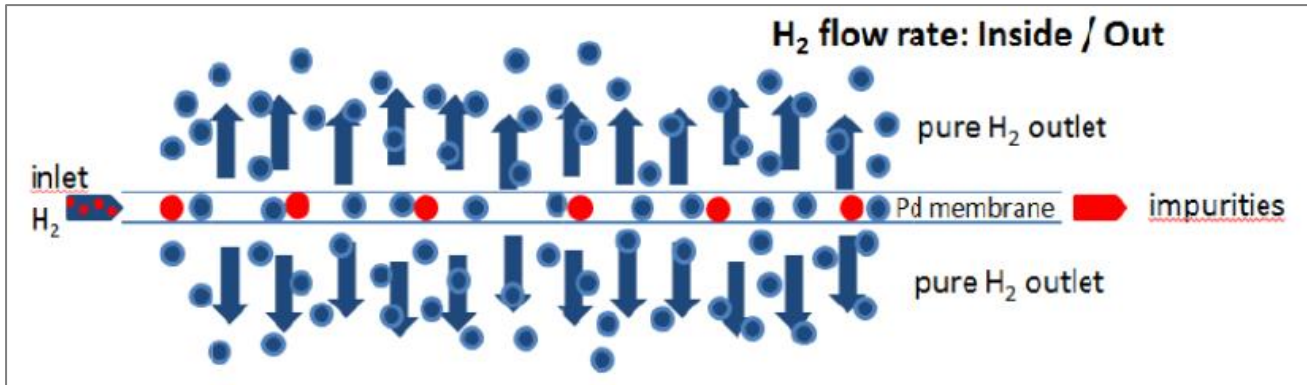

Fig. 14 Principle of operation of a Palladium membrane.

3.5. Other

Cryogenic separation – the stream of gas is cooled to cryogenic temperatures⁸, trapping all impurities with the exception of helium – which has a boiling point even lower than hydrogen at 268.9 °C – in the system. This technology is mostly used for large scale to offset the running costs of maintaining the system at cryogenic temperatures.

Metal hydride⁹ separation

Solid Polymer Electrolyte Cell

Catalytic Purification

References:

- (1) https://www.researchgate.net/publication/320129097_High_Purity_Hydrogen_Guidelines_to_Select_the_Most_Suitable_Purification_Technology

3.6. Combined production + purification

It is common that hydrogen is purified immediately after it's been produced in combined Hydrogen generators + purifiers. A few examples follow (**Fig. 15**).

PEM / Palladium diffuser process – The hydrogen gas molecule coming into contact with the palladium membrane surface dissociates into monatomic hydrogen and passes through the membrane due to gaseous pressure. On the other surface of the palladium membrane, the monatomic hydrogen is recombined into diatomic hydrogen.

Palladium electrolyzer / purifier – This process is based on using an electrolyzer cell with palladium as cathode. Since only hydrogen is capable of passing through it, at the end we get UHP hydrogen.

⁸ The cryogenic temperature range has been defined as from –150 °C to absolute zero (–273 °C).

⁹ Metal hydrides are materials containing metals or alloys bounded to hydrogen. When pressurized, most metals bind strongly with hydrogen, resulting in stable metal hydrides that can be used to store hydrogen conveniently on board vehicles. Examples of metal hydrides are LaNi₅H₆, MgH₂, and NaAlH₄.

Research suggests that the processes that use Palladium are capable of producing the driest purest hydrogen. So the above two processes are actually the ones that result in the highest quality hydrogen. For less demanding applications the following two processes can be used.

PEM / Adsorbent PSA Process – Contaminated hydrogen flows alternatively through two columns packed with adsorbent material, acting as a molecular sieve.

PEM / Silica Desiccant Process – hydrogen is produced in a PEM cell and subsequently flows through a stainless steel desiccant¹⁰ cartridge for moisture removal. The desiccant is commonly made up of silica gel beads.

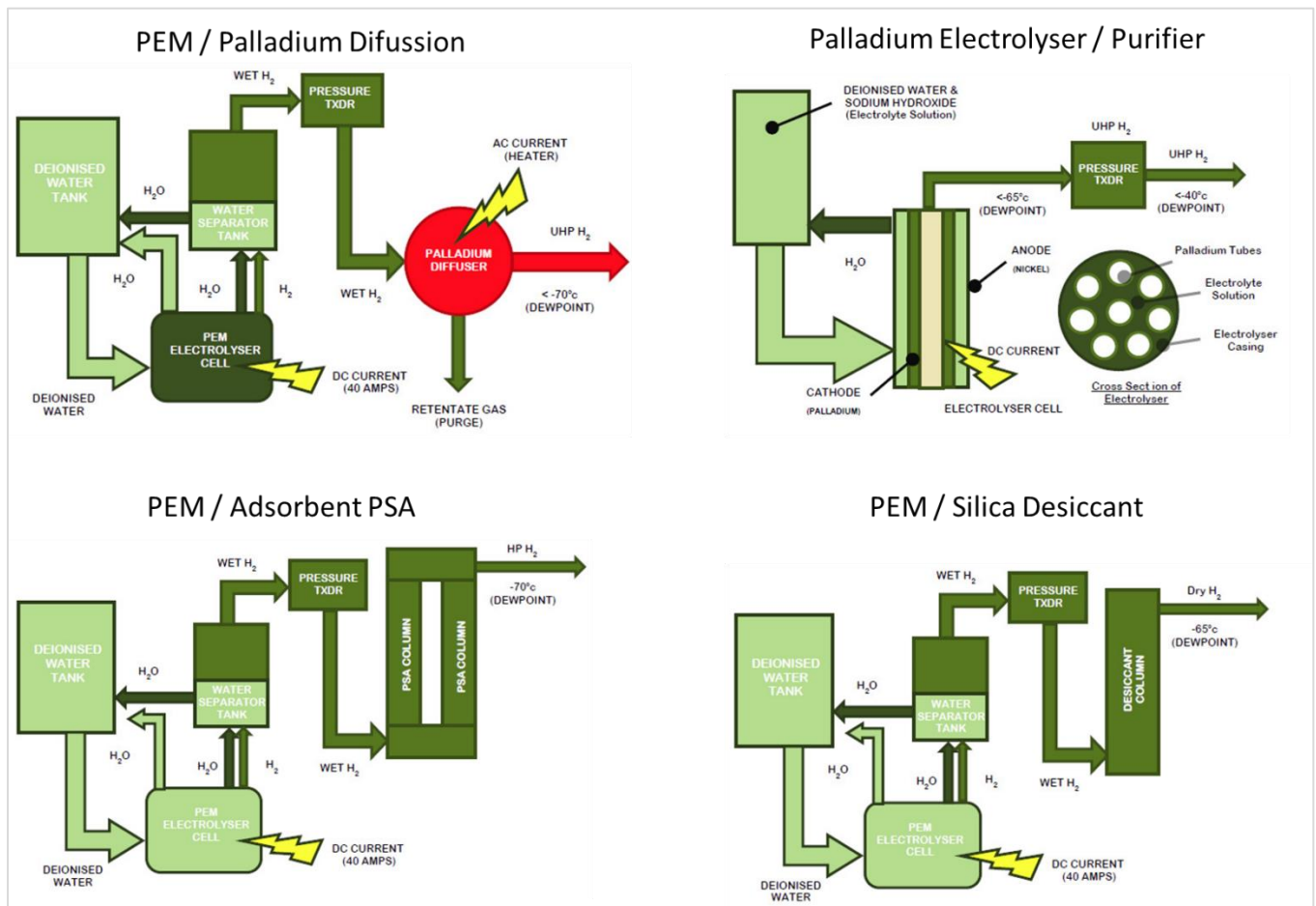

Fig. 15 Most common hydrogen purification processes. UHP = Ultra High Pure (1) (modified).

Note in reference to ‘wet hydrogen’: We say a gas is ‘wet’ when there is some amount of liquid present in it. The term describes a range of conditions varying from a humid gas which is gas saturated with liquid vapor to a multiphase flow with at least a 90% volume of gas (remember the p-v diagram Fig. 16). The opposite is ‘dry H₂’ which contains no liquid phase.

Note in reference to ‘deionized water’: Deionized Water: Water obtained by passing through ion exchange resins. Result is water without charged particles, ions. Organic particles, for e.g., can go through. Distilled

¹⁰ Desiccation is the state of extreme dryness, or the process of extreme drying. A desiccant is a hygroscopic substance that induces or sustains such a state in its local vicinity in a moderately sealed container.

Water: Water obtained after vaporization and condensation. Result is water with few to none non-volatile compounds.

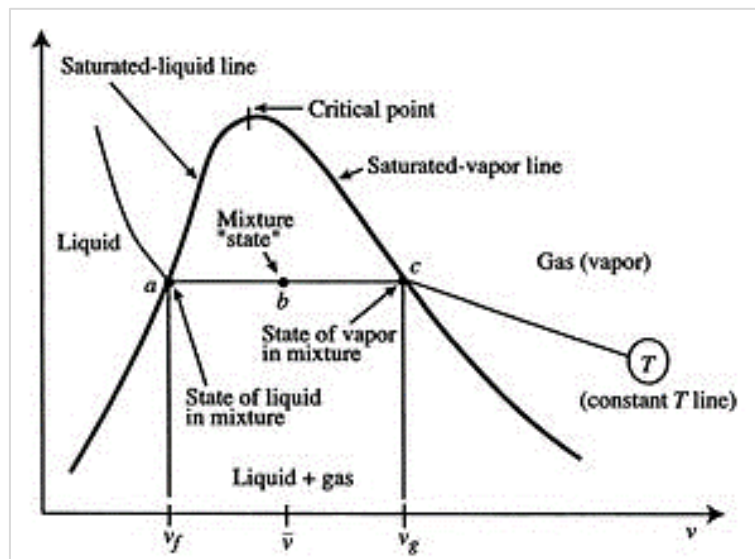

Fig. 16 General p - v diagram.

Resources

- (1) jingli-hydrogenplant.com/hydrogen-purification/hydrogen-purification-unit-hydrogen-purifier.html
- (2) peakscientific.com/articles/hydrogen-purification-methods/
- (3) sciencedirect.com/science/article/abs/pii/S0378775306025304

4. Storage and Transportation

4.1. Introduction

The rise of renewable energy, while markedly the way to go, brings forward the issue of storage and balancing supply and demand. Until now, rising water level in hydro plants have dominated electricity storage. More recently, two other energy storage technologies have begun to call for attention: hydrogen and batteries.

A relevant feature of hydrogen is its extremely high diffusivity. As the lightest gas, hydrogen can diffuse into another medium, passing through porous material or even metals. This can also cause materials to become brittle. In storage, the high diffusivity requires the use of special materials for the storage containers – for example austenitic steels or coatings with diffusion barrier layers. Otherwise, diffusion losses of the stored hydrogen can occur.

As mentioned before, even though hydrogen has a very high specific energy, it was a very low energy density. To solve this issue it is usually stored either in liquid form or highly compressed (**Fig. 17**).

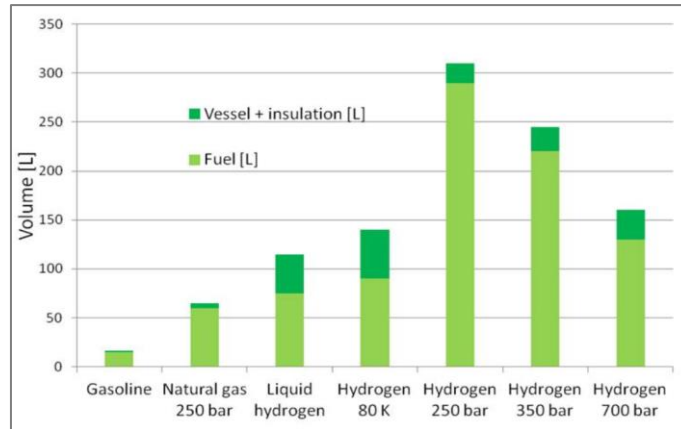

Fig. 17 Comparison of storage volume required per fuel for ~800 kJ.

Pure storage can be liquid or gaseous. Liquid storage needs to be at least $< -243\text{ }^{\circ}\text{C}$. The advantage compared to gas storage is that the storage tank does not need to deal with high pressure, “only” needs to be well thermally insulated. This means the tanks that store liquid H_2 can be lighter than those that store high pressure gas H_2 . While the tank itself can be lighter, they can require refrigeration systems if it is to be stored for long periods of time.

Liquefaction increases the density of hydrogen by a factor of around 800, and the storage volume falls correspondingly. For the purposes of comparison, when **Liquefied Petroleum Gas (LPG)** is liquefied, the density or volume factor, depending on the proportion of butane/propane, is around 250; when methane is liquefied to form **Liquefied Natural Gas (LNG)**, the factor is around 600.

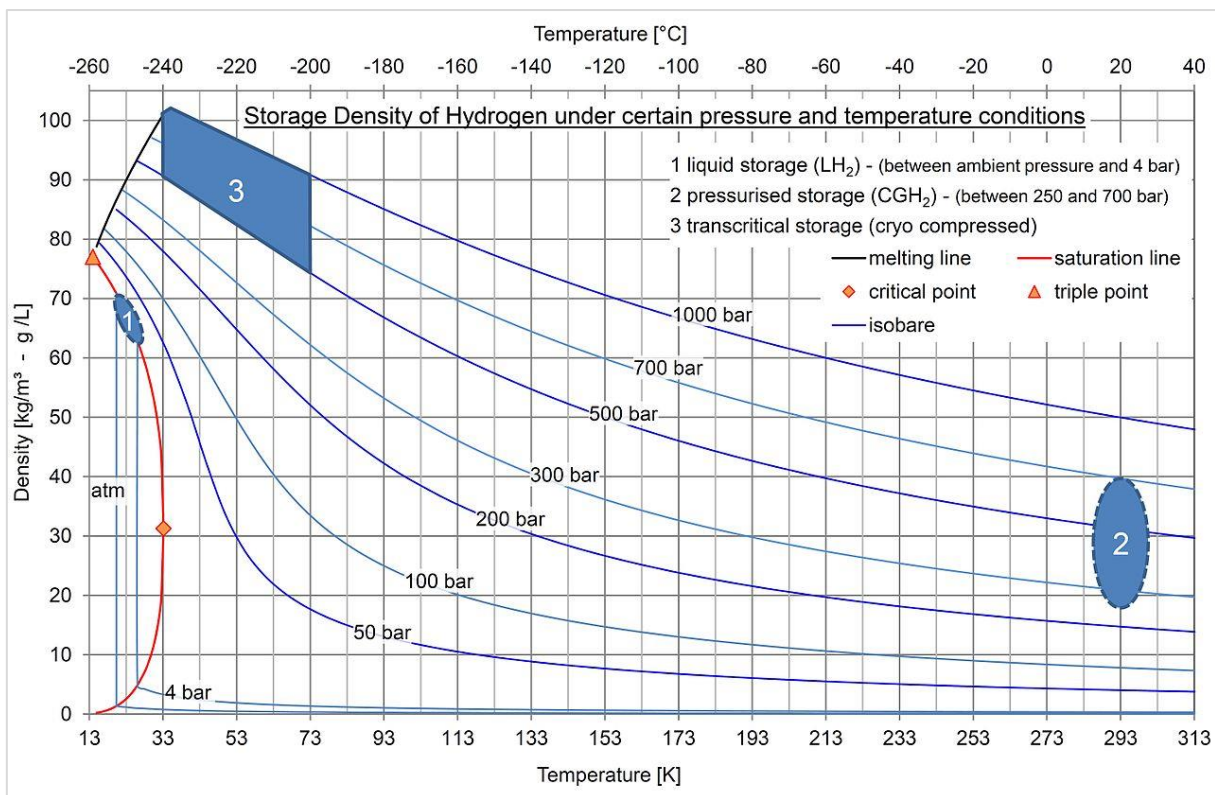

Fig. 18 Density, temperature and pressure diagram of hydrogen.

Analyzing **Fig. 18** it’s possible to observe:

Liquid hydrogen storage (region 1) – Low pressure, low temperature. Used mainly for rocket fuel, large industrial storage sites and hydrogen transportation.

High pressure, ambient temperature storage (region 2) – This is how most H₂ is stored. Note that it is an area surrounding ambient temperature (293K = 20 °C). This eliminates the need for temperature control of the stored hydrogen.

Ultra high density storage (region 3) – High pressure, low temperature. Used for stationary hydrogen storage, where the weight of the tank is of no concern and the priority is quantity (mass) of stored hydrogen.

Table 4 The basic hydrogen storage methods (1).

Storage method	ρ_m (wt%)	ρ_v (kg/m ³)	T (°C)	P (MPa)
High pressure gaseous H ₂	13	40	ambient	77
Cryogenic liquid	–	70.8	–252.87	atmospheric
Adsorbed on carbon nanotubes	10.8	41	–196.15	6
Absorbed to form hydrides	3	150	ambient	atmospheric
Absorbed to form complex hydrides	18	150	> 100	atmospheric

Hydrogen usually is supplied to the final user by one of three means: point-of-use tank, multi-tank configurations, and hydrogen generators.

A **point-of-use tank** is used to supply hydrogen and is located next to the application. This approach is used more frequently in smaller, less hydrogen intensive applications such as small laboratory use. The tank, usually a cylinder, is usually monitored to ensure that the gas supply does not run out. Alarm systems are available to warn the user that a tank is getting low. When changing tanks, the hydrogen flow must be interrupted.

Multiple hydrogen tanks connected to manifolds and a switchover system are used to supply more demanding applications. Sometimes the supply tanks are placed on the outside. The switchover system ensures that a continuous stream of hydrogen gas is available even if one of the tanks would run out of gas during an actual run or during tank changes.

In both the point-of-use systems and multiple tank systems, there is always the possibility of system air contamination occurring during replacement. If air or moisture gets into the column, damage to the stationary phase can occur. With such systems, gas traps are employed frequently. With gas tanks, there is a great deal of added attention required: inventories must be maintained, rental costs must be accounted for, and tank handling is always required.

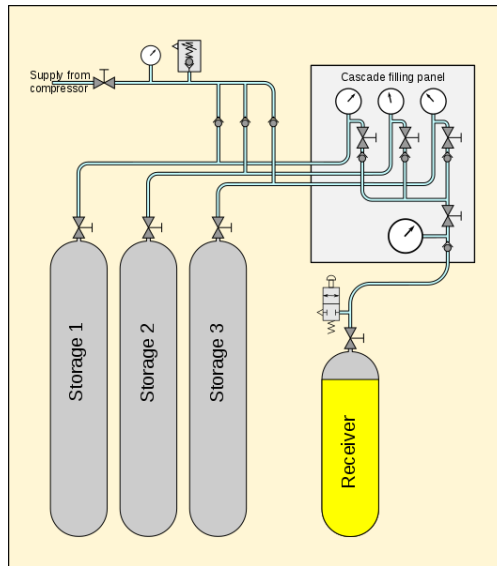

Fig. 19 Schematic diagram of a simple cascade filling system commonly used in hydrogen systems.

Finally, **in-house hydrogen generators** are becoming an accepted replacement for gas cylinders. A hydrogen generator provides a continuous stream of gas at a sufficient flow rate for the needs of the machine/instrument.



Fig. 20 From smallest to largest, Solid H₂ storage, gas hydrogen storage and liquid hydrogen storage tanks.

References

- (1) P. Nikolaidis, A. Poullikkas / Renewable and Sustainable Energy Reviews 67 (2017) 597–611

4.2. Gaseous hydrogen

4.2.1. Gaseous hydrogen storage

The major components of a high-pressure gas compression storage system are the compressor and pressure vessel.

Pressure vessel types

Hydrogen cylinders are made with different materials such as austenitic steel, aluminum alloys or carbon fibers. Depending on the pressure resistance and how they are made there are four main types of pressure vessels:

Type I – All metal construction, usually steel. Low cost $\sim 5\text{€}/\text{L}$. They are the heaviest at $\sim 1.4\text{kg}/\text{L}$. They account for about 90% of the total pressure vessel market.

Type II – Mostly steel/aluminum with glass fiber overwrap/winding in the hoop direction. The metal and composite share \sim equal parts of the load. Cost $\sim 7\text{€}/\text{L}$ and weight $\sim 1\text{kg}/\text{L}$.

Type III – Metal (usually aluminum) liner with full composite wrap (usually carbon fiber). The composite material carries the structural loads.

Type IV – Fully wrapped composite with non-metal liner.

Type V – Fully wrapped composite with no liner.

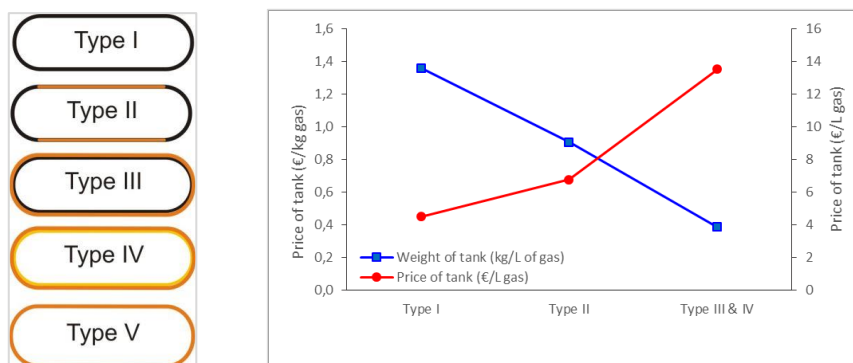

Fig. 21 Left - Types of pressure vessels and schematic representation of metal/composite composition. Right - Weight of tank per gas storage and price of tank per pound of gas versus tank type.

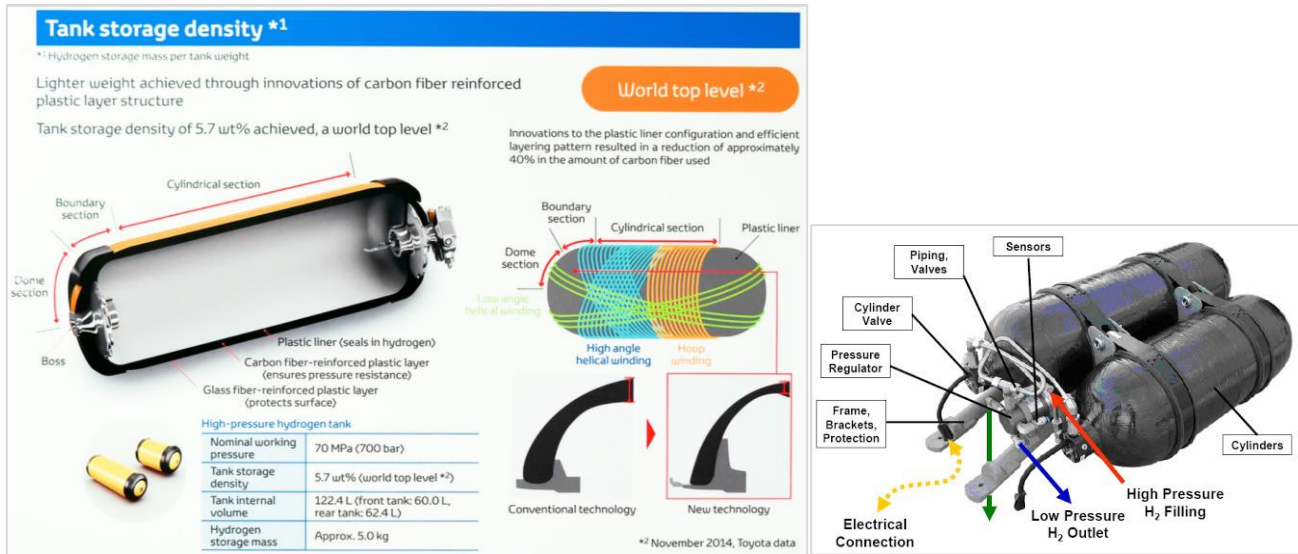

Fig. 22 Left) Carbon reinforced tank composition and characteristics; Right).

While steel pressure vessels are commonly used for high-pressure gas storage (up to 700 bar), not so much for hydrogen. Steel alone is not a desirable material because hydrogen diffuses into it, making it brittle. This problem gets exacerbated if the vessel is frequently charged and discharged (failure by embrittlement and fatigue). For use in vehicles they are also too heavy – the ratio of mass stored hydrogen and mass of vessel is low, on the order of 0.01 kg H₂ / kg vessel.

In general, the safety concerns for hydrogen storage are the same as those for storage of common fuel gases. As hydrogen gas is much lighter than air, any hydrogen leak will flow upward and disperse quickly. Accumulation of hydrogen around the source of leakage is less likely in comparison with other fuel gases. The flammability range of hydrogen in dry air at 1 bar is 4.1 to 74.8% by volume of hydrogen. For a safe operation, sufficient ventilation is required for hydrogen storage to ensure that any hydrogen leaks can be diluted to less than 1% by volume. Safety will be discussed further ahead.

Compression

In order to store hydrogen at high pressure, it must be compressed. Gas compression to low volume and high pressure is common for many gases. The main difference between compression of hydrogen and other gases is that because hydrogen has such a low density, it requires more energy per unit mass and compression ratio. The efficiency of energy storage of hydrogen gas is about 94% (3).

Because many applications have tight purity requirements, there needs to be special compressors. Compressors that do not pollute the hydrogen stream are required, which makes the technology more expensive.

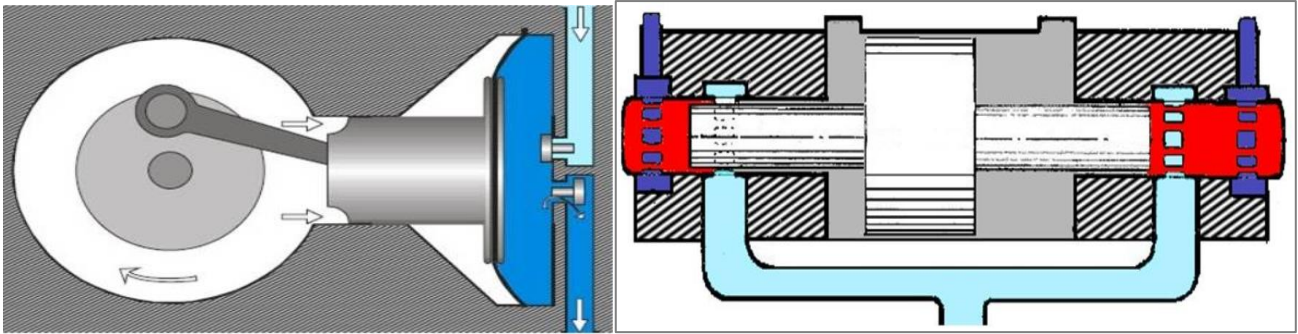

Fig. 23 Left) Membrane compressor. Right) Dry piston compressor.

Two examples of such compressors are shown in **Fig. 23**. They are ideal for hydrogen systems, since some fuel cell applications or the chemical industry require extremely high hydrogen purity. These compressors do not contaminate, or are less likely to contaminate compared to other systems. In these compressors the inlet gas has no contact with the internal mechanism so the gas remains at high purity.

These hydrogen compressors can be expensive and energy intensive because they need to be built with extremely low tolerances, and work harder to compress hydrogen gas because of hydrogen's extremely small molecular size and weight. If there is risk of contamination, filters may be necessary.

An electrochemical hydrogen compressor is one where hydrogen is supplied to the anode and collected for pressures up to 700 bar, efficiencies around 80%. Contrary to mechanical compressors electrochemical compressors work without any moving parts. These compressors are low maintenance, quiet, no vibrations, compact and reliable. Their main current disadvantage is price, especially for high compression pressures and output. Each one can compress up to 50 kg H₂ / day.



Fig. 24 HyET electrochemical hydrogen compressor.

References:

- (1) en.wikipedia.org/wiki/Cascade_filling_system
- (2) Cheng, Xuan, et al. "A review of PEM hydrogen fuel cell contamination: Impacts, mechanisms, and mitigation." *Journal of Power Sources* 165.2 (2007): 739-756.
- (3) <https://journals.sagepub.com/doi/pdf/10.1260/014459806779367455>

4.2.2. Gaseous hydrogen transportation

Regarding gaseous hydrogen distribution, the most important systems and the most used are transportation by road on trailers and through pipelines.

Road transport

This procedure is the most common hydrogen transport system in Europe. Trailers for compressed hydrogen work at 200 bar due to their mechanical and material (usually steel) limits, whereas vehicles' standard storage is 350 and 700 bar. However, it is estimated that pressure can be increased with new cylinder materials (Type 4).

Due to low density of hydrogen, a 20 000 kg – trailer can only transport 400 kg of hydrogen and only 85 % can get discharged since below a certain pressure, gas removal cannot be performed.

Pipeline networks

This is the most appropriate system to handle large amounts of hydrogen. Two scenarios should be considered:

1. New hydrogen network installation

It carries a huge initial investment (about 0.4 – 1.2 M€/km) although its maintenance and operation costs are extremely low, which make it suitable for high hydrogen demands.

It works at 100 – 150 bar in order to compete in energy content with **Compressed Natural Gas (CNG)**, due to their energy density difference.

Nowadays, there are about 1 500 km of pipeline in Europe (Germany, Belgium, France, Netherland and Great Britain mainly), which is an exiguous figure compared with the 1 850 000 km of existing pipe network for CNG (so more than 1000 x bigger)

2. Adaptation of the existing CNG network

This is a lower cost option, because pipelines up to 10% hydrogen content in volume only require light adaptations of the existing CNG network.

4.3. Liquid hydrogen

4.3.1. Liquid hydrogen storage

Hydrogen is stored as a liquid at very low temperatures (-253 °C or 20 K at 1 bar). The advantage of liquid over gaseous hydrogen is its higher volumetric energy density, resulting in reduced onsite space requirements.

Key points of this technology are associated with keeping it at cryogenic temperatures (Cryogenics is the study of low temperature physics.):

- As the storage vessel gains heat from the ambient, the stored liquid hydrogen will gradually evaporate. For safety reasons, the hydrogen vapor is vented when the pressure exceeds the critical operating pressure, resulting in a boil-off loss.
- In order to minimize the boil-off, the storage vessels are thermally insulated by materials of low thermal conductivity, evacuated double walls, and reflective metallic foils to reduce heat transfer by conduction, convection, and radiation, respectively.
- Typically, boil-off occurs about 3 days after a vessel is charged with liquid hydrogen and the boil-off rate ranges from 0.1% to 3% / day. Usually smaller vessels have higher percentages.

Storage vessels

Special insulated tanks are required for this option and are mainly composed of:

- Inner tank, which must be hydrogen contact resistant and operation temperature resistant (20 K). Also, thermal expansion should be taken into account due to temperature differences between full and empty tanks.
- Intermediate insulation layer that can be of two different types. The first one consists of an intermediate vacuum jacket with aluminum layers, with low emissivity but high reflectivity, separated by carbon fiber layers. The second type is a rigid foam insulation, with less safety problems but also more heat conductivity.
- The outer shell is made of steel or aluminum and must have a high resistance to abrasion. New materials such as fibers and compound are in development.

Liquefaction

Liquefaction is usually carried out by using the Linde cycle or Joule-Thomson expansion process. It consists of a series of stages to convert gaseous hydrogen to liquid hydrogen:

1. Gas compression at ambient temperature.
2. Gas cooling in a heat exchanger.
3. Gas passes through throttles.
4. Final expansion. Generated liquid is extracted and non-liquefied gas is refluxed

The energy required to liquefy hydrogen in an ideal Lynde cycle has been calculated to be 11.88 MJ/kg H₂ about 64% higher than the energy required for high-pressure hydrogen gas compression. Taking into account the caloric value of hydrogen of 120 MJ/kg H₂ the energy efficiency of hydrogen liquefaction storage is 91%. We don't, however, reach those ideal values, and thus the energy consumption would be 10 kWh/kg H₂ (36 MJ/kg H₂), equivalent to an energy efficiency of 77% for hydrogen storage (vs 94% of compressed hydrogen gas). Due to the high cost and low energy efficiency, hydrogen liquefaction storage is only attractive when high storage densities are required.

4.3.2. Liquid hydrogen transportation

Regarding liquid hydrogen distribution, the most transportation methods are by road on trailers, by sea and by rail.

Liquid hydrogen transport by road

It is possible to transport up to 4 000 kg of liquid hydrogen which is more than ten times than what is possible for hydrogen gas. In addition, extremely high purity levels can be maintained in liquid form.

In order to minimize evaporation losses, tanks used in this system are similar to those employed in gaseous transport by road but with a liquid nitrogen outer jacket.

Table 5 below shows a comparison between the two types of hydrogen transports by road, highlighting the more expensive liquid storage tank due to its nitrogen outer jacket.

Table 5 Comparison between two types of road transport (source: SFA Pacific).

Parameter	H2 (l) trailer	H2 (g) trailer
Charge (kg)	4 000	300
Discharge (kg)	~4 000	250
Time charge/discharge (h/journey)	4	20
Evaporation losses (%/day)	0.3	Non applicable
Tank (€)	450 000	100 000
Frame (€)	60 000	60 000
Cabin and chassis (€)	90 000	90 000
Cost (€/kg)	0.14	1.61

Despite having minimal maintenance and operating costs, the specific cost of a pipeline network is 2.26 €/kg, far more expensive than the compressed hydrogen road transport, due to the huge initial investment. On the other hand, liquid hydrogen transport by road can be up to 10 times cheaper than any other road hydrogen transport

Liquid hydrogen transport by sea

This mode of transport is yet to be available in Europe, however countries like Canada have ships designed for transatlantic hydrogen transport of up to 21.2 ton.

Liquid hydrogen transport by rail

Liquid hydrogen transported by train is suitable for distances of 1 500 km and above. This kind of transport can use cylindrical tanks similar to what is used for road transport.

4.4. Hydrides

Hydrid materials will absorb hydrogen like a sponge, and then release it when heated. Hydrides are very effective for storing large amounts of hydrogen in a safe and compact way, avoiding some of the disadvantages of gaseous storage (high pressures and bulky units) and liquid storage (very low temperatures). Storage of hydrogen in hydride materials is relatively new compared with pressure vessel storage and liquid hydrogen storage. The storage materials are too heavy for commercial use in vehicles with reasonable traveling range. Metal hydride storage may be a suitable option when weight is not a major concern, i.e. stationary power plant.

Hydrogen reacts with many transition metals and their alloys to form metal hydrides. The reaction of hydrogen gas with a metal to form the hydride is described as follows:

1. Molecular hydrogen (H₂) moves to the metal's surface.

2. Molecular hydrogen is located on the metal surface due to a small attractive force between the metal and H₂ molecule.
3. The hydrogen molecule is separated, or dissociated to form monatomic hydrogen atoms.
4. The monatomic hydrogen atoms are ionised to form an H⁺ and electron pair.
5. The hydrogen ion H⁺ occupies the interstitial sites of the metal lattice structure and the electron is donated to the host metal electron cloud.

The absorption process is exothermic and desorption requires heat. As hydrogen is absorbed, the heat generated must be removed or recovered simultaneously to minimize the loss in storage capacity due to the increase in temperature. The heat removed may be stored and later used to release the hydrogen from the hydride storage during discharging. Depending on the hydrogen absorbing material used, the heat generation ranges from 9 to 23 MJ/kg of hydrogen.

Although metal hydride storage has very high volumetric storage density (> 100 kg H₂/m³), the gravimetric storage density is very low due to the heavy metals or alloys. The storage density of hydrides storage is between about 0.02 - 0.06 kg H₂/kg. Hydrides storage working around ambient temperature and pressure would normally have gravimetric storage density of about 0.03 kg H₂/kg.

Heat of reaction, will be 23 250 kJ/kg for absorption of hydrogen. Assuming that 50% of this energy can be recovered for desorption use, then the energy for one charging/discharging cycle will be about 11,600 kJ/kg. Assuming a pressure of 20 bars for hydrogen in the reactor vessel, the compression energy will be around 4 000 kJ/kg. The total energy required for hydrides storage will thus be (11.6 + 4.1) MJ/kg or 15.7 MJ/kg. With a CV of 120 MJ/kg for hydrogen, this can be translated into an energy storage efficiency of about 88% for metal hydrides storage.

There are several metal hydrides used in hydrogen storage depending on the composition:

Intermetallic hydrides

They are alloys of metallic elements. They are widely used in hydrogen storage due to their good stability, reversibility and kinetics.

Intermetallic compounds contain two or more metallic elements, producing different crystal structures and properties upon absorption of hydrogen. An intermetallic hydride composition is represented by the ternary system A_mB_nH_x. The A element is usually a transition metal located left in the periodic table or rare earth metal that tends to form a stable hydride. The B element is often a transition metal from the right side and forms only unstable hydrides. Some ratios of B to A have been found to form hydrides with a hydrogen to metal ratio of up to two, like AB (FeTi), A₂B (Mg₂Ni), AB₂ (TiMn₂) and AB₅ (LaNi₅).

Binary hydrides

Consisting of a binary compound of hydrogen with a metal, they contain a high hydrogen mass content, making them attractive for storage applications. The dehydrogenation reactions are usually slow and require high temperatures (~300 °C), so their use is limited until a solution to this is found. For instance, MgH₂ 7 wt% desorbs at 300 °C but researchers have obtained interesting results by adding 2 wt% Ni which reduces the desorption temperature to 150 °C.

Complex hydrides

Complex hydrides involve hydrogen atoms forming ligands with other atoms attached to other metal structures. These structures are usually formed by metal-hydrogen complexes such as $[\text{AlH}_4]$, $[\text{NH}_2]$ and $[\text{BH}_4]$, with fixed hydrogen atoms and an ionic structure with electropositive alkaline or alkaline earth metal elements.

Compounds like $\text{Li}[\text{BH}_4]$ reach hydrogen-rich configurations of 18 wt%. Complex hydrides are known to have a high volumetric energy density although they have a low gravimetric energy density, so they are suitable for stationary applications but not for mobile applications.

4.5. Chemical storage

Another hydrogen storage strategy consists of creating intermediate compounds for storage and transport. Useful compounds for chemical storage must have the following characteristics:

- High volumetric energy density.
- To be liquids at ambient temperature for easy transport.
- Easy hydrogen recovery from intermediate compounds.

Compounds used for chemical storage have the same amount of hydrogen, such as CH_4 , CH_3OH , NaAlH_4 , NaBH_4 , etc. However, most of these compounds are difficult to produce due to their reversibility. More recently ammonia (NH_3) has also been considered as a possible medium for energy / hydrogen storage (2).

References:

- (1) <https://www.sciencedirect.com/topics/engineering/hydrogen-storage>
- (2) <https://www.sciencedirect.com/science/article/abs/pii/S0360319918339272>

5. Safety

Hydrogen is a highly flammable and explosive gas, with wide flammability limits, a low minimum ignition energy and a fast burning velocity. In the atmosphere, its flammable mixture can rapidly disperse in air, but in confined spaces its deflagration generates a severe pressure impulse and may result in detonation.

Many believe that hydrogen is particularly dangerous. There are some that think hydrogen energy is related to the hydrogen bomb. But, hydrogen used as a fuel involves a simple chemical reaction involving the transfer of electrons to produce an electric current while a hydrogen bomb requires a high temperature nuclear fusion reaction similar to that which occurs in our sun and other stars.

Due to the fact that hydrogen is a colourless and odourless gas and can react with certain metals, special attention needs to be paid to its propensity to leak, its ability to form flammable mixtures, its various ignition sources and use of proper storage materials. Similarly, special attention needs to be paid to liquid hydrogen as boil-off can readily produce hydrogen gas.

Care needs to be taken into account with liquid hydrogen due to its low temperature which can cause frostbite, thermal stress, fast evaporation and solidification of moisture in air. Regarding “solid hydrogen”, or metal hydrides, its fine particles are often pyrophoric, leading to an internal stress that can result in the rupture of the storage tank. These hazards are not substantially different from other commodity chemicals and fuels and

with the proper regulations and protocols, hydrogen can be safely handled, either in gaseous, liquid or solid form .

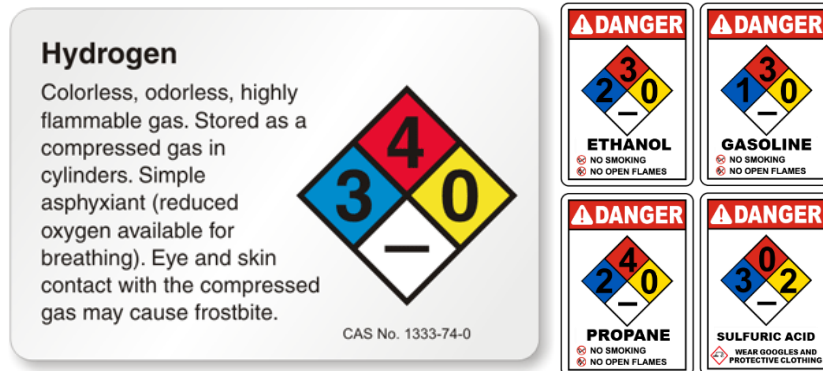

Fig. 25 Hydrogen safety rating according to NFPA 704. Other dangerous substances’ danger sticker for comparison (2 modified).

Note: CAS number is a unique number attributed by an American institution (Chemical Abstracts Service) to every substance known for identification purposes. Hydrogen’s is 1333-74-0. See relevant annex for more information on how to interpret the rating.

Resources:

- (1) en.wikipedia.org/wiki/NFPA_704
- (2) newenv.com/resources/nfpa_chemicals/

5.1. Injuries

These are the possible injuries that can result from handling hydrogen:

Asphyxiation	If H2 or inert gas used for purging the system displaces oxygen in the breathing atmosphere.
Blast overpressure	Resulting from detonation.
Burn	Resulting from a direct contact with a H2 fire, thermal radiation or contact with surface heated by H2 fire.
Fragments	Explosion can produce fragments which can result in injury.
Frostbite	Can result from mishandling LH2.
Hypothermia	LH2 spill can lower body temp as a consequence of cold environment

5.2. Combustion

Three things are needed for a fire or explosion to occur: a fuel, oxygen (mixed with the fuel in appropriate quantities) and a source of ignition. Hydrogen, as a flammable fuel, mixes with oxygen whenever air is allowed to enter a hydrogen vessel, or when hydrogen leaks from any vessel into the air. Ignition sources take the form of sparks, flames, or high heat.

When talking about combustion three concepts that the reader may not be familiar with need to be introduced:

Concept of **Flammability Limit** (FL) [% v/v] and **flammability range**. The **Lower Flammability Limit** (LFL) and the **Upper Flammability Limit** (UFL) represent the limit concentrations of fuel in air/oxygen that the combination (fuel + air/oxygen) will burn. These limits may change with temperature and pressure, but are usually expressed at STP for comparison purposes.

Minimum Ignition Energy (MIE) [J] can be defined as the minimum amount of energy that sets a mixture of a specified flammable material with oxygen or air on fire. This is usually measured according to specific standards depending if the materials is powder (solid), liquid, or gaseous. For the examples below (**Table 6**) an electric discharge spark was used.

The **Autolgnition Temperature** (AIT) [°C] is the lowest temperature at which a substance spontaneously self-ignites in normal atmosphere, that is, without an external source of energy, such as a flame or spark. The energy from the high temperature supplies the activation energy needed for combustion to start.

Hydrogen is extremely flammable (**Table 6**). This is partly mitigated by its low density, which causes it to quickly disperse in the air. If it cannot disperse (for example in case of there being a roof) appropriate measures need to be taken such as proper ventilation, having a roof that can be safely blown away in the event of an explosion. When hydrogen is burned in ambient air, the flame is scarcely visible in daylight, since the flame is characterized by low heat radiation and a high ultraviolet component. If combustion takes place, the only safe way of handling a hydrogen fire is to let it burn under controlled conditions until the hydrogen flow can be stopped. Neither hydrogen nor its combustion products are toxic.

The **maximum flame propagation rate** is 3 m/s in air.

Table 6 Minimum ignition energy and auto-ignition temperature of some common substances. (1),(2)

Substance	MIE (mJ)	AIT (°C)	Flashpoint (°C)
hydrogen	0.011	~550	-253
diesel	0.24	210	
ethane	0.24	515	
propane	0.25	480	-104
butane	0.26	470	
methane	0.3	580	-188
gasoline	0.8	~270	-43
sugar	30	~350	
wood	30	250	
coal	40	~525	

A spark of static electricity from rubbing of dry clothing against each other is enough to ignite hydrogen.

Distinction should also be made between a flammable and a combustible substance. **Flammable** substances are those that can easily catch fire (i.e. have a flash point) at temperatures below 38 °C, **combustible** substances require a higher temperature than 38 °C to catch fire.

All fuels burn only in a gaseous or vapor state. Fuels like hydrogen and methane are already gases at atmospheric conditions, whereas other fuels like gasoline or diesel that are liquids must convert to a vapor before they will burn.

The characteristic that describes how easily these fuels can be converted to a vapor is the **flashpoint**. The flashpoint is defined as the temperature at which the fuel produces enough vapors to form an ignitable mixture with air at its surface.

If the temperature of the fuel is below its flashpoint, it cannot produce enough vapors to burn since its evaporation rate is too slow. Whenever a fuel is at or above its flashpoint, vapors are present.

So a liquid only burns because it vaporizes in the surface and it is those vapors that burn? So a substance in liquid state cannot burn, only its gas? What about solids then like coal?

The flashpoint is always lower than the boiling point. For fuels that are gases at atmospheric conditions (like hydrogen, methane and propane), the flashpoint is far below ambient temperature and has little relevance since the fuel is already fully vaporized. For fuels that are liquids at atmospheric conditions (such as gasoline or methanol), the flashpoint acts as a lower flammability temperature limit.

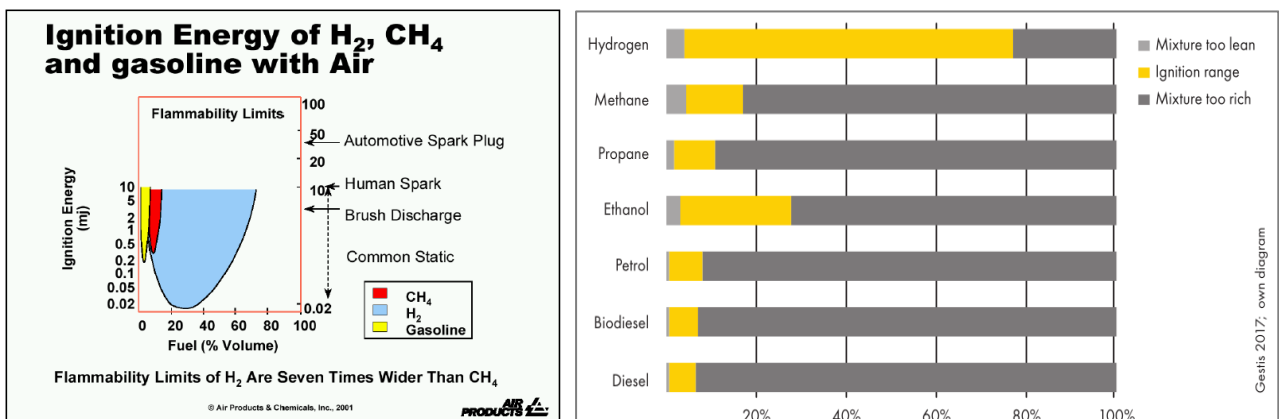

Fig. 26 Left) Flammability limits vs minimum ignition energies of H₂, CH₄ and gasoline in air at NTP. Right) Ignition range of fuels.

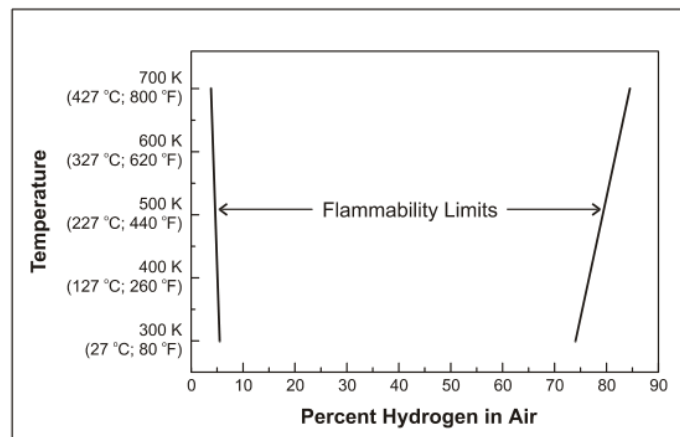

Fig. 27 Variation of flammability limits of hydrogen in air with temperature. (3)

The flames of combustion of hydrogen are nearly invisible which makes them hard to avoid and hard to fight. Special equipment may be needed in order to properly visualize them.

Combustion can vary in degree of violence:

A **fire** is a stationary flame with the flammable mixture fed into the reaction zone.

A **deflagration** is a subsonic propagation of a combustion flame in the unreacted medium.

A **detonation** is a supersonic propagation of a combustion flame in the unreacted medium.

An **explosion** is the bursting or rupture of an enclosure or container due to the development of internal pressure from a deflagration or detonation.

Two related concepts are the lower explosive limit (LEL) and the upper explosive limit (UEL). These terms are often used interchangeably with LFL and UFL, although they are not the same. The LEL is the lowest gas concentration that will support an explosion when mixed with air, contained and ignited. Similarly, the UEL is the highest gas concentration that will support an explosion when mixed with air, contained and ignited.

An explosion is different from a fire in that for an explosion, the combustion must be contained, allowing the pressure and temperature to rise to levels sufficient to violently destroy the containment. For this reason, it is far more dangerous to release hydrogen into an enclosed area (such as a building) than to release it directly outdoors.

In a crash or accident where hydrogen is released, it rapidly disperses up and away from the ground and any combustible material within the area. Gasoline and other hydrocarbon fuels are heavier since the hydrogen is bonded to carbon which is a much heavier element.

When hydrocarbon fuels vaporize, their gases tend to sink rather than rise into the atmosphere. This allows burning gasoline to cover objects and burn them. In most accidents, hydrogen would be a more desirable fuel.

References

- (1) explosionsolutions.co.uk/110411020.pdf
- (2) en.wikipedia.org/wiki/Flammability_limit
- (3) Hydrogen Properties, College of the Desert, 2011.

5.3. Toxicity and asphyxiation

Hydrogen is not toxic. Asphyxiation is the state or process of being deprived of oxygen. In this sense it doesn't matter whether it's hydrogen or any other gas – the risk is the same. This means that should you breathe too much hydrogen you could die of asphyxiation simply for being deprived of oxygen. Because, like oxygen, it has no odor taste or visibility, you won't necessarily know that you're breathing it.

5.4. Storage and overpressure

The largest risk is located in the gas tank which is prone to leaking or in extreme cases, rupturing.

Apart from manufacturing defects, ruptures can occur due to impact with sharp objects, improper handling, stress fracture, an external fire, failure of the pressure relief valve, or failure in the fuel line connection. To prevent this, many solutions can be adopted, such as a safe design of the system to prevent shock and

vibration, leak detectors or mixing odorants in the fuel. Also, mechanisms to prevent ignition in case of an accident should be in place, like an automatic disconnection of the battery, separation of fuel lines and electrical systems as well as proper ventilation of the systems.

Concerning LH₂ storage, LH₂ has a significant expansion ratio in its conversion from liquid (at boiling point) to gas (normal temp and pressure) which, if appropriate venting is not allowed, will cause an abnormally high pressure to build up inside the storage vessel. We call this overpressure. If this excessive pressure can cause deformation or rupture on the vessel and subsequent release of H₂ and possible projectiles from vessel fragments.

5.5. Detection

Hydrogen being odorless, tasteless and colorless makes it hard for human detection of leaks and highlight the importance of detection systems.

Any area where leaks, spills or hazardous accumulations may occur require the use of sensors, either fixed or portable which must be compatible with other systems, such as those for fire detection and fire suppression.

While hydrogen gases can be hard to see with the naked eye, they show on ultra-violet / infra-red flame detectors.

Understanding sensor measurement values: In air pollution literature ppm applied to a gas, always means parts per million by volume or by mole. These are identical for an ideal gas, and practically identical for most gases of air pollution interest at 1 atm (1). In this way, it is possible to convert to volume percentage as 10 000 ppm = 1% (v/v or n/n).

A reliable hydrogen detection systems consists of

1. Identification of all possible sources to be monitored (valves, flanges, connections, etc.);
2. Evaluation of the expected response time of the leak detection system to be compatible with the responding safety system;
3. Installation of visual and audible alarms for above-limit conditions, but still in the safe range;
4. Provision of portable detectors for field operations or isolated areas and fixed detectors for remote-automated operations;
5. Periodical calibration of sensors;
6. Correct distribution of sampling points based on the possible leak and ventilation rate and adjusted to the area size.

References:

- (1) [sciencedirect.com/science/article/abs/pii/S0160791X05000266?via%3Dihub](https://www.sciencedirect.com/science/article/abs/pii/S0160791X05000266?via%3Dihub)
- (2) [nrel.gov/docs/fy17osti/64076.pdf](https://www.nrel.gov/docs/fy17osti/64076.pdf)
- (3) hydrogenandfuelcellsafety.info/
- (4) Never, N. , Air Pollution Control Engineering. McGraw-HILL, Singapore 1995.

5.6. Hazard mitigation

To-dos for H₂ risk mitigation:

- Hydrogen pipes situated above other gas pipes. (H₂ rises up, can prevent contact with other gas pipes with minor leaks during H₂ leak).
- Proper ventilation system.
- Hydrogen sensors where leak may occur and where H₂ accumulates.
- UV/IR monitoring system to detect H₂ flames.
- Internal piping pressure and flow rate monitors.
- Control system to initiate automatic H₂ shutdown when any of the criteria does not match.
- Visual and audible alarms
- Portable leak detectors to detect localized leak.
- Regular safety check ups of the system.

In general, liquid hydrogen storage is more hazardous than high-pressure hydrogen gas compression storage as:

1. Unlike hydrogen gas, liquid hydrogen is heavier than air. Therefore, in case of leakage, liquid hydrogen flows downwards and accumulates before it vaporizes;
2. Boil-off hydrogen vapor must be vented to a safe location clear from any source of ignition;
3. The safety valve and vent of a storage vessel may be clogged by ice due to the cooling of moist air. The subsequent pressure build-up may cause the vessel to rupture;
4. Liquid hydrogen is subject to contamination of air condensed onto equipment during repeated charging and discharging. The mixture can then be easily ignited. It is important to prevent air condensation or oxygen enrichment by proper insulation and sealing. Condensed air mist must not be allowed to drop onto combustible materials such as tar and asphalt to avoid creation of a local explosive mixture;
5. Air leaking into liquid hydrogen can lead to fire or explosion. The pressure of the storage vessel must be maintained above the atmospheric pressure to prevent air from entering the vessel.

6. Applications

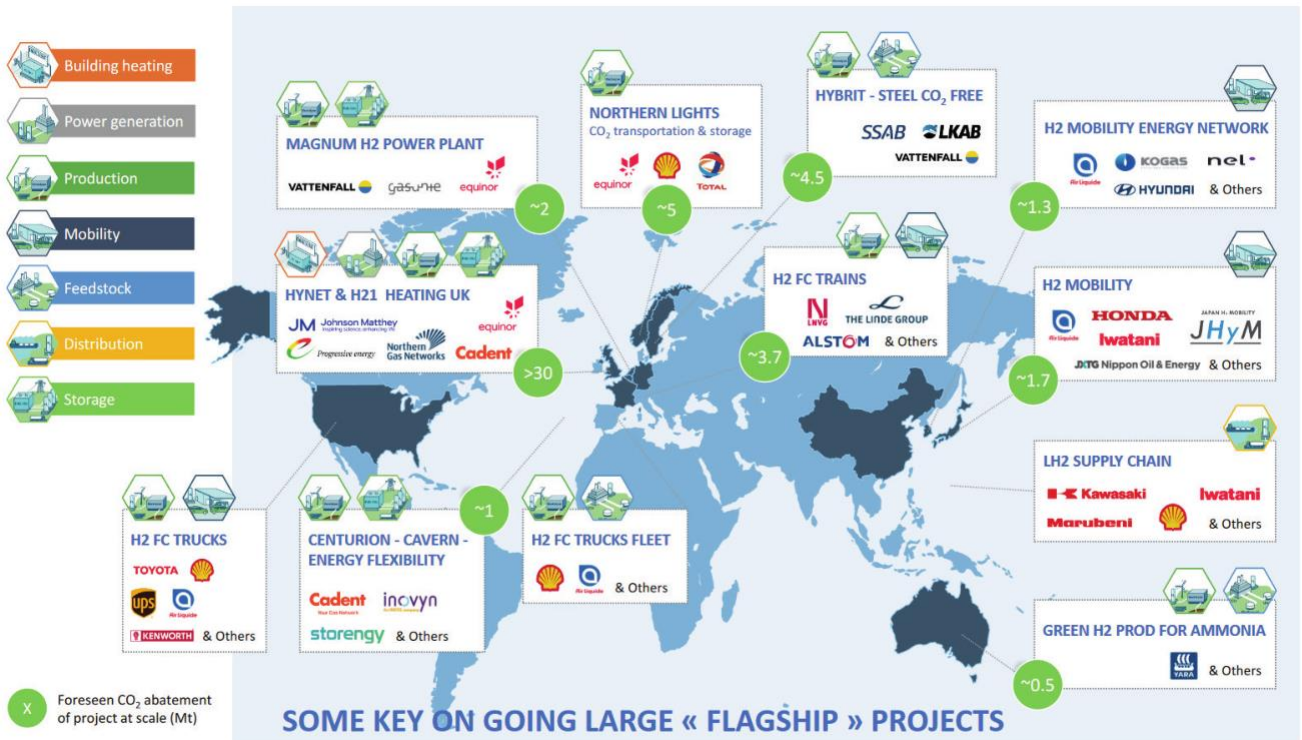

Fig. 28 Key on going large 'flagship' projects around the world (1).

Most of the hydrogen currently produced is used as feedstock to make other materials, mainly due to its chemical properties, rather than its energetic properties.

Total hydrogen use in the EU, in TWh

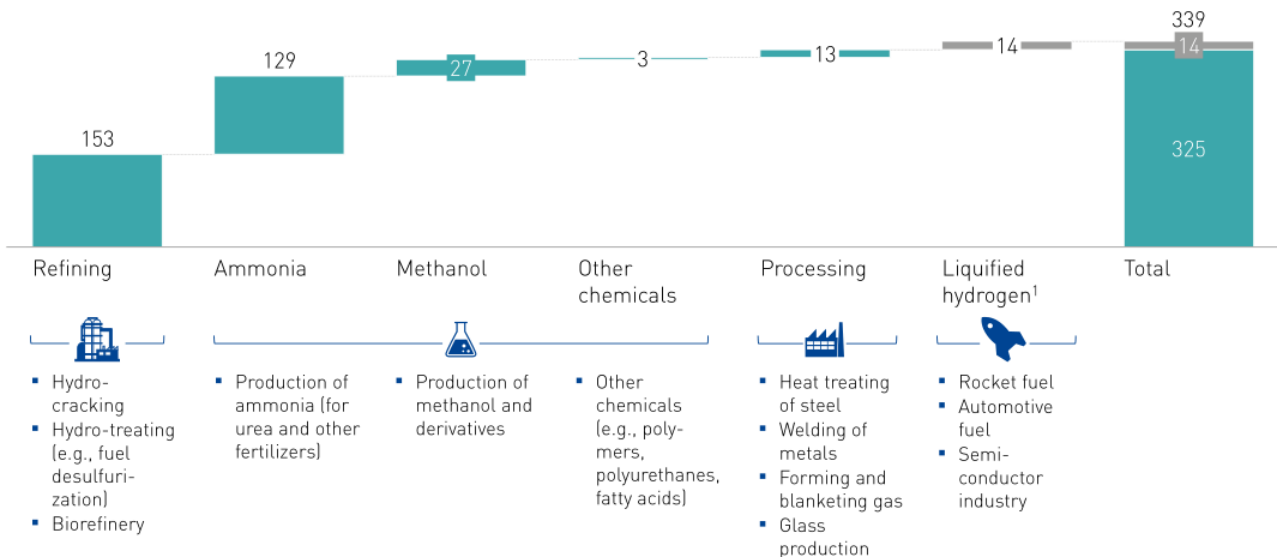

Fig. 29 Use of Hydrogen today.

References:

- (1) Waterstof: kansen voor de Nederlandse industrie (2019)

(2) Hydrogen Roadmap Europe (2019), pp. 40.

6.1. Transportation

Automobiles, trucks, airplanes, boats, trains, forklifts. Consider vehicles where the battery would have to be impractically large.

Some companies argue that adding small amounts of gaseous hydrogen and oxygen to the fuel just before combustion (Internal Combustion Assistance) they can increase the efficiency of diesel engine (~25%), reduce particulate matter (85%) and NOx (~70%) (1).

6.1.1. Aviation

There are quite a few companies trying their luck into hydrogen powered aviation. Typically airplanes uses jet fuel (either pure kerosene or a mixture of kerosene with gasoline).



Fig. 30 ZeroAvia's zero emission hydrogen powered airplane for short-haul flights (2).

References

- (1) [vox.com/energy-and-environment/2018/2/16/16926950/hydrogen-fuel-technology-economy-hytech-storage](https://www.vox.com/energy-and-environment/2018/2/16/16926950/hydrogen-fuel-technology-economy-hytech-storage)
- (2) [zeroavia.com](https://www.zeroavia.com)

6.1.2. Rockets

In combination with an oxidizer such as liquid oxygen hydrogen has the highest specific impulse of any known rocket propellant (1). Specific impulse can be thought of as how much each bit (unit mass) of the fuel propels the engine forward (thrust). As can be seen in Fig. 31, theoretically hydrogen is the most promising of known fuels. The issue remains: while per kg it provides a lot of energy, per volume not so much. It needs to be highly compressed and thermally insulated resulting in a heavy, large tank compared to using a HC fuel. Moreover, the tank and all tubing needs to be properly prepared for leakages, which with H₂ are very easy to happen. SpaceX has opted to use a kerosene fuel because they optimize for cost over performance. While using H₂ might be more efficient, the technical challenges and cost at the end are currently greater.

Hydrogen is far easier to ignite than HC such as methane, butane, kerosene and gasoline. Comment on this

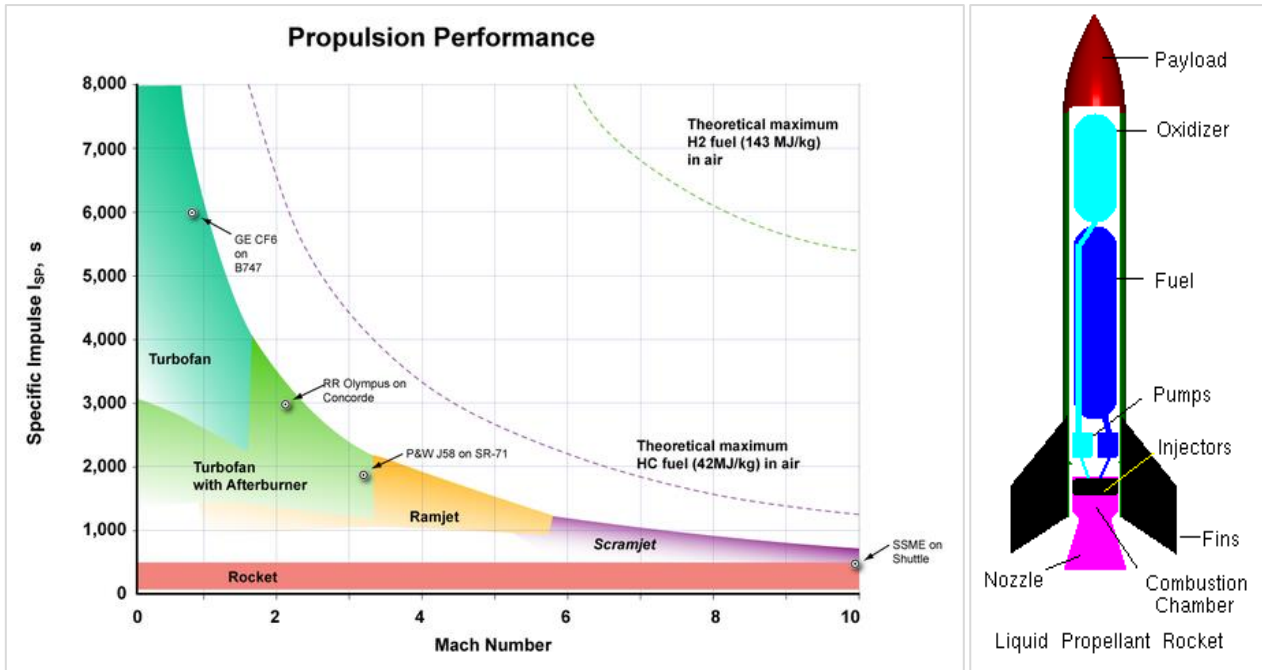

Fig. 31 Left: Specific impulse and theoretical maximums for a hydrocarbon rocket (HC) fuel and H₂ rocket fuel (2). Right: Simple schematic of rocket propellant mechanism (3).

References

- (1) nasa.gov/topics/technology/hydrogen/hydrogen_fuel_of_choice.html
- (2) en.wikipedia.org/wiki/Specific_impulse
- (3) grc.nasa.gov/www/k-12/rocket/TRCRocket/practical_rocketry.html

6.2. Industry

6.2.1. # Hydrogenation

Hydrogenation is a process that uses hydrogen gas to add hydrogen molecules to a substance.

The largest application is in the food industry for processing vegetable oils where they are changed from liquid into a hard spread / margarine. Hydrogenation stabilizes the oil and prevents spoilage from oxidation. It is also used in the petrochemical area to convert alkanes and aromatics into paraffins (saturated alkanes) and naphthenes (cycloalkanes), which are less toxic and reactive. In organic chemistry hydrogenation is used to convert unsaturated into saturated compounds.

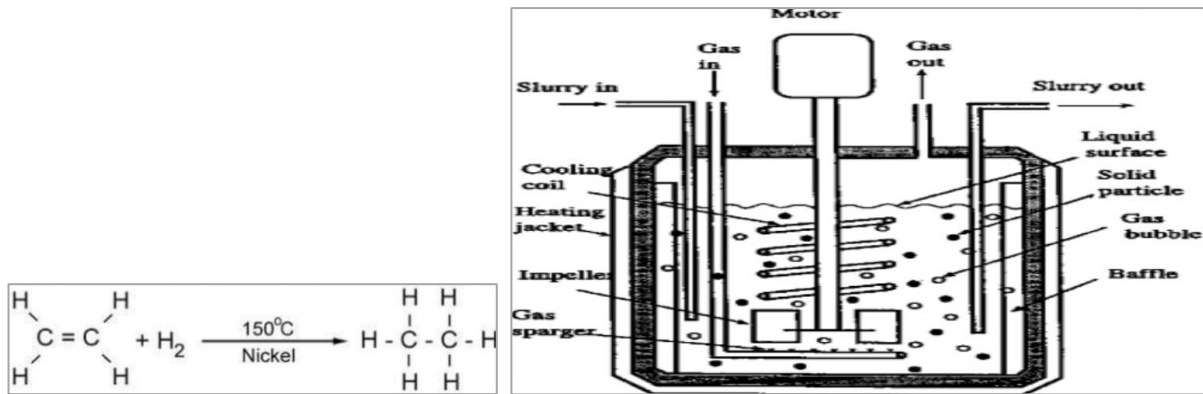

Fig. 32 Left: Hydrogenation of Ethylene, becoming Ethane. Right: Schematic of a typical hydrogenation machine.

References:

- (1) en.wikipedia.org/wiki/Hydrogenation#Industrial_applications
- (2) slideshare.net/prathameshkudalkar7/hydrogenation-of-oils

6.2.2. Ammonia

Ammonia (NH₃) is one of the most commonly produced chemicals in the world which means there is already a large infrastructure for making, transporting, and distributing ammonia. The production is usually through fixation of nitrogen from the air in the Haber ammonia process (Fig. 33). ~90% of ammonia goes into fertilizers. Due to its high energy of evaporation it is also used in refrigeration with the technical name of R-717.

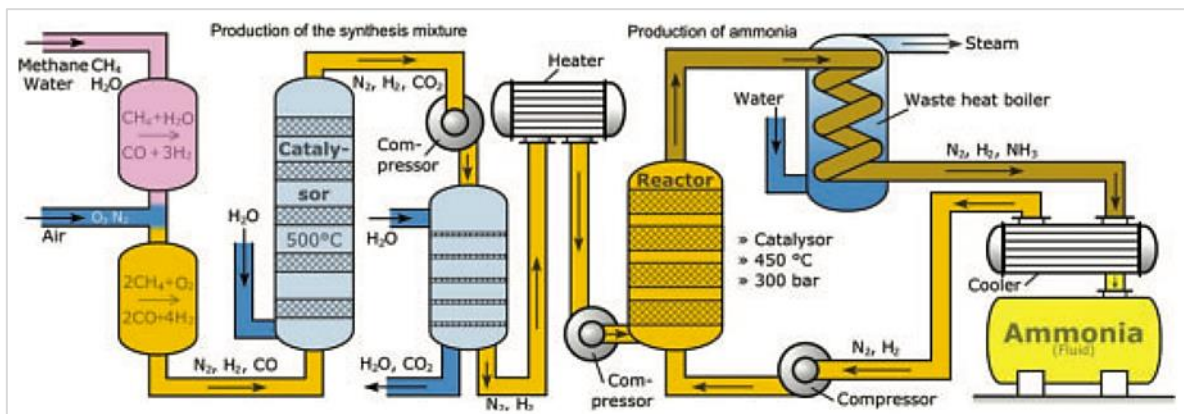

Fig. 33 Schematic representation of the ammonia production through the Haber-Bosch process.

Ammonia can also serve as a means of hydrogen storage with mild pressurization and low temperature requirements. It can be liquefied at only 33°C or 8.5 bar and contains 18wt% of hydrogen (Fig. 34). It can alternatively be used directly as a fuel. Since it has no carbon, no carbon by-products are produced, making it a possible carbon-neutral energy carrier. It has 18.6 MJ/kg energy density at NTP. However ammonia is toxic and has a strong odor.

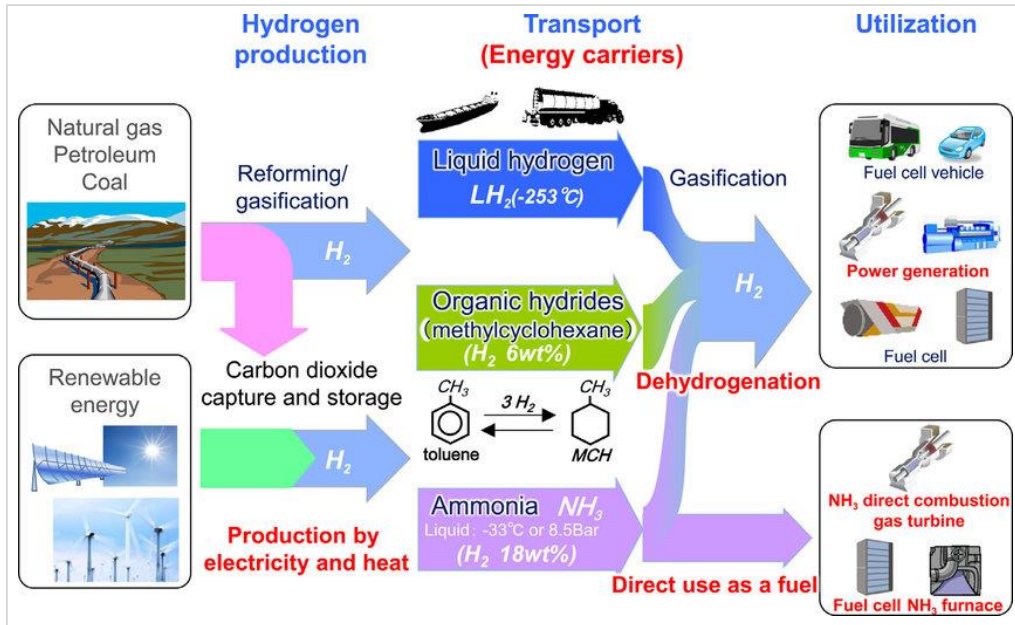

Fig. 34 Context of ammonia production in the general H₂ production. (1)

Resources:

- (1) [researchgate.net/publication/328854439](https://www.researchgate.net/publication/328854439) Science and technology of ammonia combustion

6.2.3. # Welding

Some specific applications use atomic hydrogen welding, an arc welding process where hydrogen is used as shielding gas between the two tungsten electrodes. Hydrogen in its atomic state is a strong reducing gas which prevents oxidation of weld metal. Where does this hydrogen in atomic state come from though? When the arc is struck between the two electrodes the heat generated between the two dissociates hydrogen molecule into its atomic form.

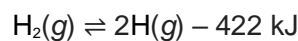

As the atomic hydrogen touches the cold piece it recombines into its molecule form liberating the same amount of energy. This exothermic reaction results in the 3rd hottest flame, reaching temperatures of up to 4000 °C.

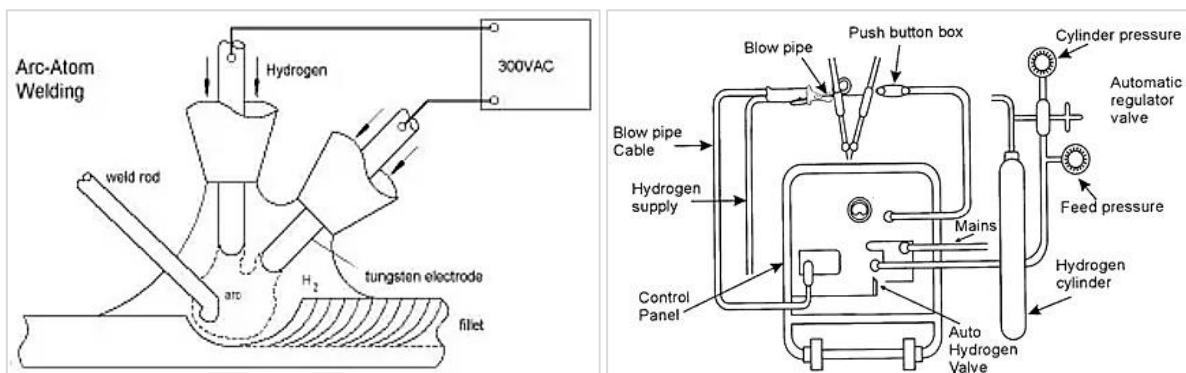

Fig. 35 Left: Atomic hydrogen welding explaining diagram. Right: Atomic Hydrogen Welding Equipment. (1)

Currently, as a standalone shielding gas, it's mostly used in applications where rapid welding is necessary such as stainless and special alloys.

Lately it has also been used as an additive to Metal Inert Gas and Tungsten Inert Gas shielding gases in order to increase the efficiency of melting **Fig. 36**.

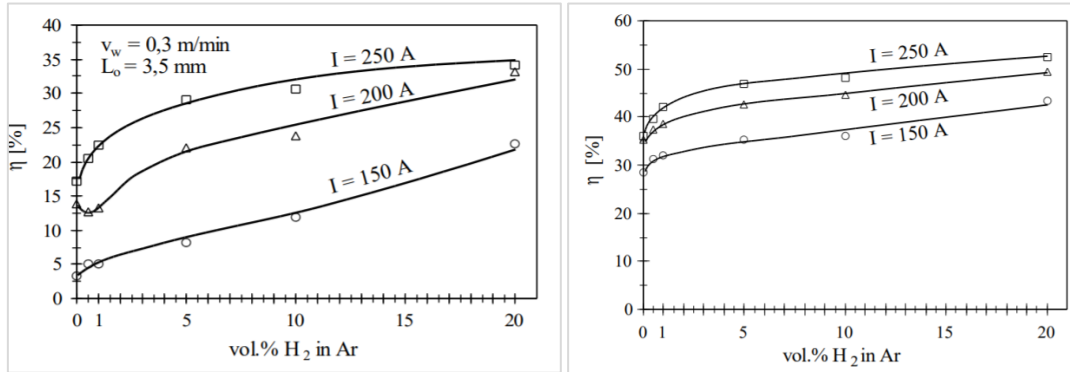

Fig. 36 Influence of hydrogen concentration in argon shielding gas on melting efficiency in TIG (left) and MIG (right) welding. (2)

On the market there are devices that produce the hydrogen (**Fig. 37**) for welding on site

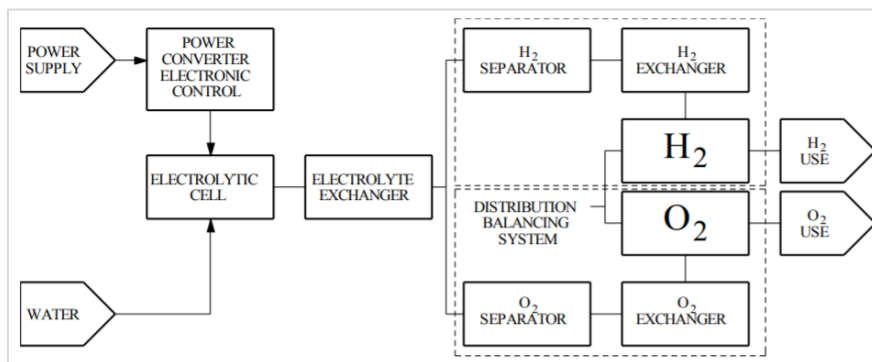

Fig. 37 Scheme of an oxy-hydrogen generator. (2)

References

- (1) [quora.com/What-is-the-principle-behind-the-atomic-hydrogen-torch](https://www.quora.com/What-is-the-principle-behind-the-atomic-hydrogen-torch)
- (2) [sciencedirect.com/science/article/abs/pii/S0924013601009566](https://www.sciencedirect.com/science/article/abs/pii/S0924013601009566)

6.2.4. # Float glass production

Float glass is a type of glass with an extremely uniform and smooth surface, with good optical properties. For this reason it is used in several applications such as building windows, solar panels, LCD displays, auto windscreens, among others.

Raw material is sand, dolomite, limestone, scrap glass, among other additives. This mixture is heated to temperatures of around 1500 °C forming a molten glass. This is then poured on top of molten tin, which acts as a smooth surface for the glass to solidify on (**Fig. 38**).

In float glass manufacturing nitrogen (~10%) and hydrogen (~90%) gases are needed in very large quantities for preventing oxidation to the molten tin where float glass is formed. Oxidation of the tin would result in defects in the resulting glass. Instead the hydrogen reacts with the hydrogen preventing oxidation of the tin.

Many glass manufacturing companies take impure hydrogen then purify it in their own premises before using it.

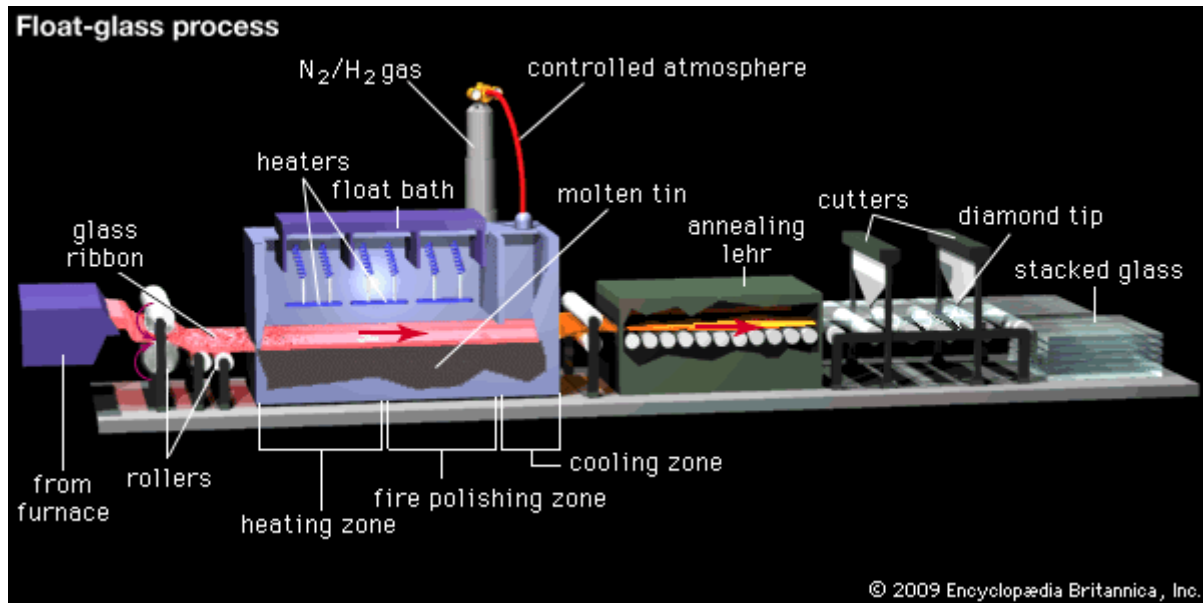
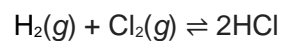

Fig. 38 Representation of the float glass manufacturing process.

6.2.5. # Production of Hydrogen Chloride

The majority of its production is for its aqueous solution known as Hydrochloric Acid. From here the largest production of hydrochloric acid is integrated with processes that there is no need for hydrogen production. When hydrogen is directly used in its production, the chemical reaction is



Some of the uses of hydrogen chloride:

- Most hydrogen chloride is used in the production of hydrochloric acid.
- Hydrochlorination of rubber.
- Production of vinyl and alkyl chlorides.
- Chemical intermediate in other chemical production.
- Used in toilet bowl cleaner.
- Use as babysitting flux.
- Treatment of cotton.
- Separation from wool.
- Used in semiconductor industry (in pure grade).
- Etching semiconductor crystals.
- Converting silicon to SiHCl₃ for purification of silicon.

6.2.6. Reduction of metallic ores.

6.2.7. GC/MS applications

Gas Chromatography and Gas Chromatography / Mass Spectrometry are methods used to identify substances within a test sample. This is used in areas such as drug detection, fire investigation, environmental analysis, identification of unknown samples (from other planets), among others. GC/MS which uses a combination of GC and MS is considered the gold standard for this purpose.

In this process hydrogen is used as a carrier gas. Helium had been the most commonly used carrier gas for GC due to its inertness, good purity, excellent performance, and well-established methodologies. In recent years, the demand for helium has outstripped the supply, resulting in limited supplies in certain geographies, increased costs, and uncertain delivery.

In gas chromatography, the carrier gas serves as the mobile phase and carries (moves) the solutes (**Fig. 39**). In this application, the hydrogen purity with respect to oxygen and water is not particularly critical. However, the hydrocarbon content of this gas must be minimized to keep low background noise.

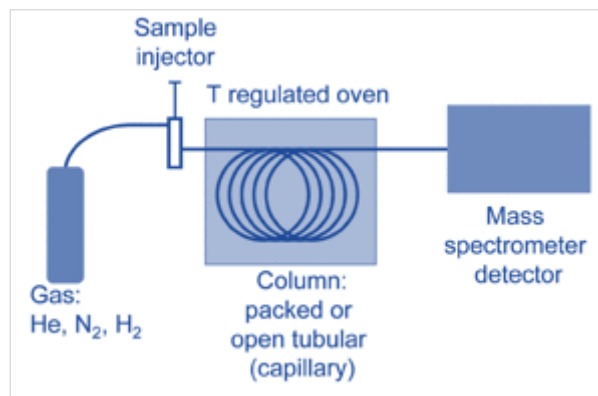

Fig. 39 GC-MS process schematic (1).

References:

- (1) en.wikipedia.org/wiki/Gas_chromatography%E2%80%93mass_spectrometry

6.2.8. Crude oil processing

To process crude oil into refined fuels, in their removal of contaminants such as Sulphur from them.

6.2.9. Gas turbines

(c.f. EUTurbines).

6.2.10. Semiconductor industry

It is widely used to grow epitaxial layers to make devices on silicon and in the compound semiconductor industry. It is also used in extreme ultraviolet lithography to make smaller and smaller geometrical patterns.

6.2.11. Steel industry

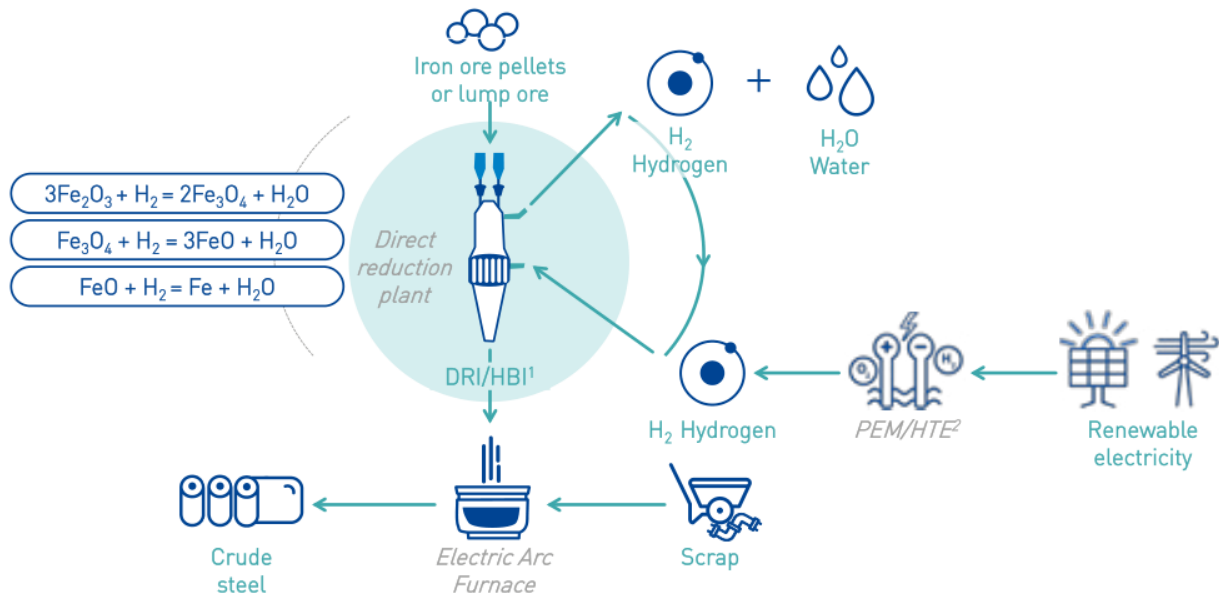

1 Direct reduced iron/hot briquetted iron
 2 Polymer electrolyte membrane electrolysis/high temperature electrolysis

Fig. 40 Deeply decarbonized steel-making through hydrogen-based direct reduced iron.

6.3. Domestic

Hydrogen is a very promising substitute for natural gas for domestic heating, seeing that it requires very little changes to existing infrastructure. Deployment will likely start first in countries that have extensive existing natural gas infrastructure and substantial amount of old buildings. The Netherlands, Germany, France and the UK fall into this category (Fig. 41).

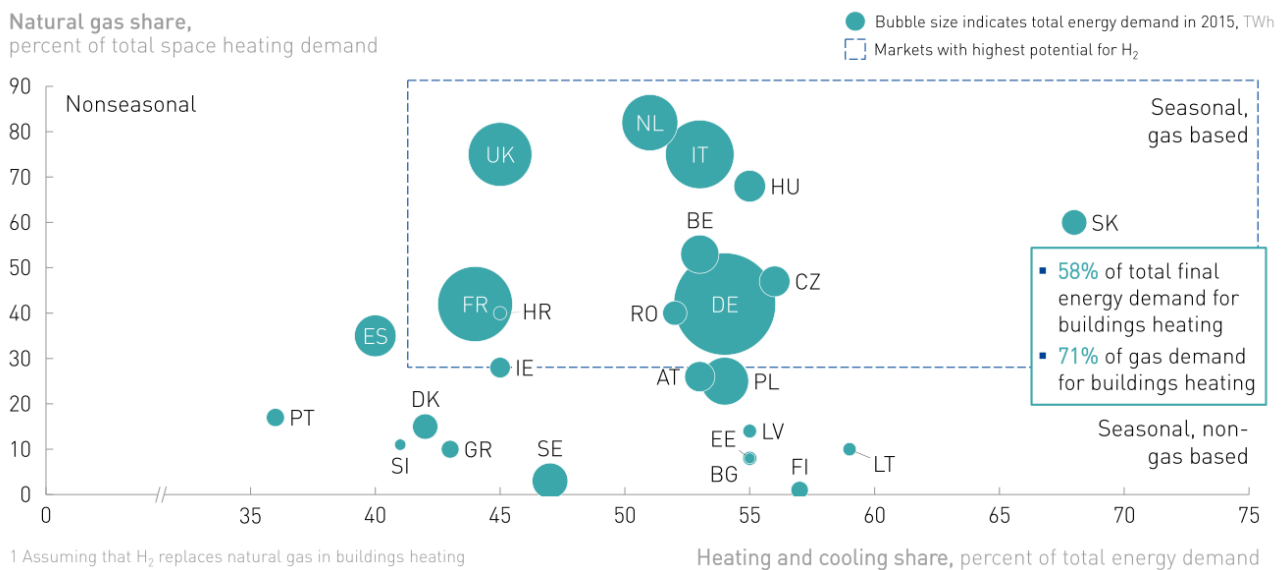

Fig. 41 Priority countries for hydrogen adoption within the EU.

Portable hydrogen producer

References:

- (1) [amazon.com/Sport-Portable-Hydrogen-Generator-Bottle/dp/B07FKVYYL6?ref_=fscfp_pl_dp_2&th=1](https://www.amazon.com/Sport-Portable-Hydrogen-Generator-Bottle/dp/B07FKVYYL6?ref_=fscfp_pl_dp_2&th=1)
- (2) Hydrogen Roadmap Europe (2019), pp. 37.

6.4. Science

In cryogenics and study of superconductivity (melting point is just above 0 K).

References:

- (1) hydrogeneurope.eu/hydrogen-applications

7. The Hydrogen Fuel Cell

7.1. Working mechanism

A **Fuel cell** is an energy conversion device. It converts chemical into electrical energy. Contrary to a battery, it cannot be depleted, we can see it more as a factory. As long as there is a fuel (e.g. hydrogen) and an oxidizing agent (usually oxygen), it will continue to generate electricity. At a minimum, a fuel cell must contain two electrodes (an anode and a cathode) separated by an electrolyte. Fuel cell power is determined by a fuel cell size. Fuel cell capacity (energy capacity) is determined by the fuel reservoir size.

A comparison of the most used fuel cells can be viewed in the annex **Fuel cell comparison**. While there are several types of fuel cells, the one that we are the most interested in because it is the most used is the **PEM** (**Proton-Exchange** or **Polymer Electrolyte Membrane**). What distinguishes the PEM from other fuel cells is the ability to function at lower temperatures.

The main events that occur within a PEM fuel cell are represented below (**Fig. 42**).

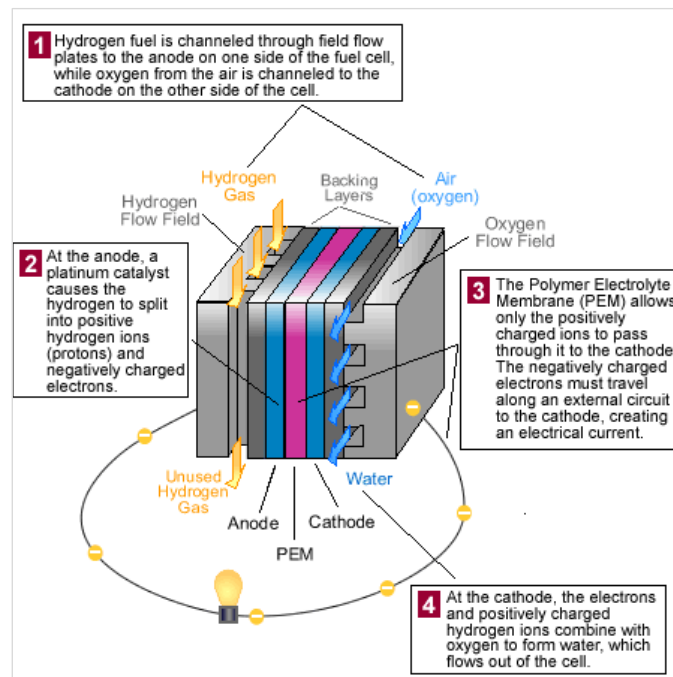
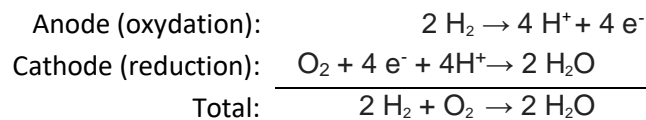

Fig. 42 Schematic of a typical hydrogen PEM fuel cell (3).

Electrochemical systems must contain two coupled half reactions : an oxidation reaction and a reduction reaction. An oxidation reactions liberates electrons while a reduction reaction consumes electrons. Oxidation reaction occurs at the anode electrode while the reduction reaction occurs at the cathode electrode. The chemical reactions that occur in a fuel cell are:



Fuel cell performance can be assessed by current-voltage curves or polarization curves (**Fig. 43**). Ideal fuel cell performance is dictated by thermodynamics.

Based on $\Delta G/\Delta H$ (ratio of change of Gibbs free energy and enthalpy) for the formation of water from hydrogen and oxygen, the efficiency of a hydrogen fuel cell should be nearly 80 % (corresponding to a cell potential of 1.23 V). In practice, the maximum cell potential of a hydrogen fuel cell is 0.95 - 1.0 V because of polarization losses as the electrode surface. Under load, losses of energy due to resistance are significant and the true cell potential ends up being between 0.6 and 0.8 V. Real fuel cell performance is always less than ideal fuel cell performance due to losses.

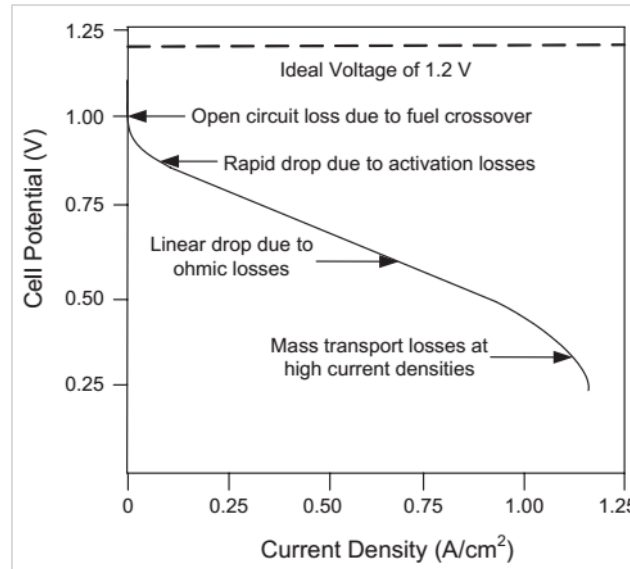

Fig. 43 Typical polarization curve for a H₂ PEM fuel cell.

There are three major loss factors in a fuel cell:

1. Kinetic.
2. Ohmic.
3. Mass transfer.

$$V = E_{thermo} - \eta_{kin} - \eta_{ohmic} - \eta_{mass}$$

V = real voltage output of a cell

E_thermo = thermodynamically predicted fuel cell voltage output

Firstly, at the low load region, we will see a large drop of voltage from a theoretical 1.23V to about 0.8V or so. This is the **kinetic loss** due to the very slow reduction reaction in the cathode side. This in turn requires a large overpotential (voltage loss) to drive any practical current density. Palladium is currently the best commercial catalyst at reducing this loss. In this region, the ohmic loss and mass transfer loss are not significant.

With increasing load, while the kinetic loss continues taking place, there is an **ohmic loss** adding in as well. This is due to the internal resistance of the fuel cell, mainly from the PEM membrane.

Lastly, at high current density, we may see another quick drop of voltage. This is due to the **mass transport** issue that the reactants cannot be delivered to the catalyst sites quickly enough, either due to the low porosity of the electrode, or due to water flooding, or anything that prevents the reactant flow.

Each cell only provides us ~0.7 V at a current density of 1 A / cm², which is not particularly useful for most applications. So what we do is we stack them in series to increase that voltage in what we call a **fuel cell stack**. The potential power generated by a fuel cell stack depends on the number and size of the individual fuel cells that comprise the stack. The power from a fuel cell stack with $n = 10$ single cells with an area $A = 100 \text{ cm}^2$ is calculated below.

$$P = V \cdot I = n \cdot v \cdot A \cdot i = 100 \cdot 0.7 \cdot 100 \cdot 1 = 700W$$

For a way to predict the fuel cell polarization curve depending on active area, number of cells, operating temperature and inlet gases pressure, please refer to (4).

References:

- (1) afdc.energy.gov/vehicles/how-do-fuel-cell-electric-cars-work
- (2) researchgate.net/publication/333446536_Hydrogen_Fuel_Cell_Vehicles_Current_Status_and_Future_Prospect
- (3) fuelconomy.gov/feg/fcv_PEM.shtml
- (4) fuelcellstore.com/blog-section/how-to-predict-fuel-cell-performance

7.2. Types

7.2.1. AFC

Alkaline Fuel Cells (AFC) are best known for their roles in the NASA Apollo mission to provide both water and electricity to the crew. These fuel cells use porous electrolytes saturated with an alkaline solution and have an alkaline membrane as the name suggests. The AFC is one of the most efficient types of fuel cells, with a potential of 60% electrical efficiency. They are highly sensitive and can fail when exposed to carbon dioxide, which is why they are primarily used in controlled aerospace and underwater applications.

These fuel cells are closely related to conventional PEM fuel cells, except that they use an alkaline membrane instead of an acid membrane. The high performance of AFCs is due to the rate at which electro-chemical reactions take place in the cell. A key challenge for this fuel cell type is that it is susceptible to poisoning by carbon dioxide. In fact, even the small amount of CO₂ present in the air can dramatically affect cell performance and durability due to carbonate formation. Challenges for AMFCs include tolerance to CO₂, membrane conductivity and durability, higher temperature operation, water management, power density, and anode electrocatalysis.



Fig. 44 AFC Energy's "POWER-UP", the world's largest operational AFC system at Air Products' industrial gas plant in Germany (1).

References:

- (1) bioenergyinternational.com/heat-power/afc-energy-and-peel-environmental-to-assess-feasibility-of-uks-largest-hydrogen-fuel-cell-precinct

7.2.2. MCFC

Molten Carbonate Fuel Cells (MCFCs) are a recently developed FC for natural gas and coal-based power plants for electrical utility, industrial, and military applications. They include an internal reformer which means, besides using pure H₂, they can also use fossil fuels for the production of electricity. MCFCs are high-

temperature fuel cells that use an electrolyte composed of a molten carbonate salt mixture suspended in a porous, chemically inert ceramic lithium aluminum oxide matrix. Because they operate at high temperatures of 650°C, non-precious metals can be used as catalysts at the anode and cathode, reducing costs.

MCFC, when used in conjunction with waste heat energy capture, can reach fuel efficiencies approaching 85%, considerably higher than the 37% – 42% efficiencies of a PAFC plant.

The primary disadvantage of current MCFC technology is durability (currently 40 000 h).

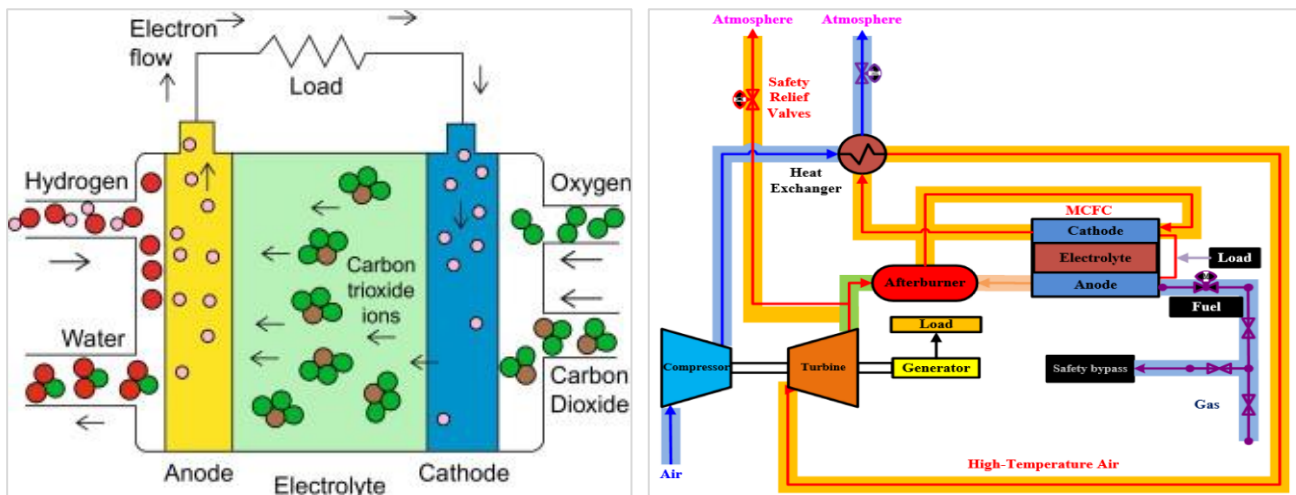

Fig. 45 Left) Schematic of MCFC working mechanism (1) ; Right) MCFC hybrid power system diagram (2).

The direct reforming MCFC hybrid power system is shown (Fig. 45). Air is pressurized by a compressor. This compressed air is then delivered to the heat exchanger to recover waste heat released by the MCFC. Next, the heated air expands in the turbine that drives both the compressor and the generator. The exhaust gas from the turbine flows into the oxidizer, in which an oxidation reaction occurs with the remaining fuel that escapes from the MCFC anode outlet. Then, the gas that contains abundant carbon dioxide goes into the cathode channel of the MCFC. The advantages of this hybrid power system are that the operating pressure of MCFC is almost equal with the atmospheric pressure and the waste heat of the MCFC is sufficiently used.



Fig. 46 DFC300 250 kW MCFC (2).

References:

- (1) [sciencedirect.com/topics/engineering/molten-carbonate-fuel-cell](https://www.sciencedirect.com/topics/engineering/molten-carbonate-fuel-cell)
- (2) [mdpi.com/1996-1073/12/11/2192/htm](https://www.mdpi.com/1996-1073/12/11/2192/htm)

7.2.3. PEM

Polymer Electrolyte Membrane Fuel Cells (PEM or PEMFC) – also called proton exchange membrane fuel cells – deliver high power density (W/kg FC and W/cm³) compared with other fuel cells. PEM fuel cells use a solid polymer as an electrolyte and porous carbon electrodes containing a platinum or platinum alloy catalyst. They need only hydrogen, oxygen from the air, and water to operate. They are typically fueled with pure hydrogen supplied from storage tanks or reformers.

PEM fuel cells operate at low temperatures, compared to other FCs, at around 80°C. This allows them to start quickly (less warm-up time) and results in less wear on system components, resulting in better durability. However, it requires a noble-metal catalyst (typically platinum) to be used to separate the hydrogen's electrons and protons, adding to system cost. The platinum catalyst is also extremely sensitive to carbon monoxide poisoning, making it necessary to employ an additional reactor to reduce carbon monoxide in the fuel gas if the hydrogen is derived from a hydrocarbon fuel. This reactor also adds cost.

PEM fuel cells are used primarily for transportation applications and some stationary applications. Due to their fast startup time and favorable power-to-weight ratio, PEM fuel cells are particularly suitable for use in passenger vehicles, such as cars and buses.

7.2.4. PAFC

Phosphoric Acid Fuel Cells (PAFCs) use liquid phosphoric acid as an electrolyte. The PAFC is considered the "first generation" of modern fuel cells. It is one of the most mature cell types and the first to be used commercially. This type of fuel cell is typically used for stationary power generation, but some PAFCs have been used to power large vehicles such as city buses.

PAFCs are more tolerant of impurities in fossil fuels that have been reformed into hydrogen than PEM cells, which are easily "poisoned" by carbon monoxide because carbon monoxide binds to the platinum catalyst at the anode, decreasing the fuel cell's efficiency. PAFCs are more than 85% efficient when used for the co-generation of electricity and heat but they are less efficient at generating electricity alone (37% – 42%).

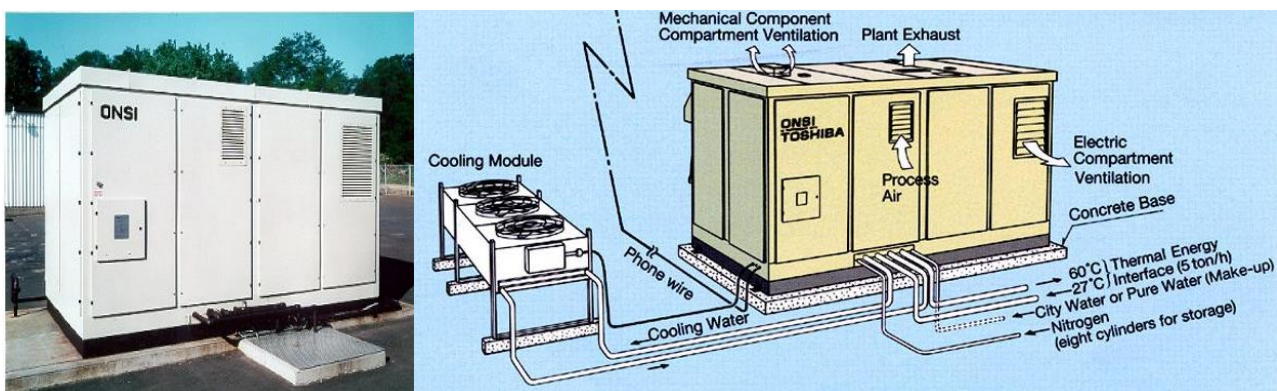

Fig. 47 Left) ONSI PC25 PAFC (200 kW) ; Right) ONSI-Toshiba PAFC (1).

References:

- (1) fuelcell.no/fuel_cell_types_pafc_eng.htm

7.2.5. RFC

Reversible Fuel Cells (RFC) produce electricity from hydrogen and oxygen and generate heat and water as byproducts, just like other fuel cells. However, reversible fuel cell systems can also use electricity from solar power, wind power, or other sources to split water into oxygen and hydrogen fuel through a process called electrolysis. Reversible fuel cells can provide power when needed, but during times of high power production from other technologies (such as when high winds lead to an excess of available wind power), reversible fuel cells can store the excess energy in the form of hydrogen. This energy storage capability could be a key enabler for intermittent renewable energy technologies.

Resources:

- (1) [energy.gov/eere/fuelcells/downloads/fuel-cell-technologies-office-multi-year-research-development-and-22](https://www.energy.gov/eere/fuelcells/downloads/fuel-cell-technologies-office-multi-year-research-development-and-22)

7.2.6. SOFC

Solid Oxide Fuel Cells (SOFCs) use layer of non-porous ceramic as the electrolyte which at high temperatures allows for the conductivity of oxygen ions. SOFCs are around 60% efficient at converting fuel (hydrogen can be one of them) to electricity. In applications designed to capture and utilize the system's waste heat (co-generation), overall fuel use efficiencies can reach 85%.

SOFCs operate at the highest temperature of any FC, as high as 1000°C. High-temperature operation removes the need for precious-metal catalyst, thereby reducing cost. It also allows SOFCs to reform fuels internally, which enables the use of a variety of fuels and reduces the cost associated with adding a reformer to the system.

Because SOFCs are sulfur and carbon monoxide resistant, natural gas, biogas, and gases made from coal can be used as fuel.



Fig. 48 Siemens Westinghouse 100 kW SOFC (Left) and its main modules (Right) (1).

References:

- (1) fuelcell.no

7.2.7. Comparison

Below (Fig. 49) a comparison between some properties of the FC above mentioned.

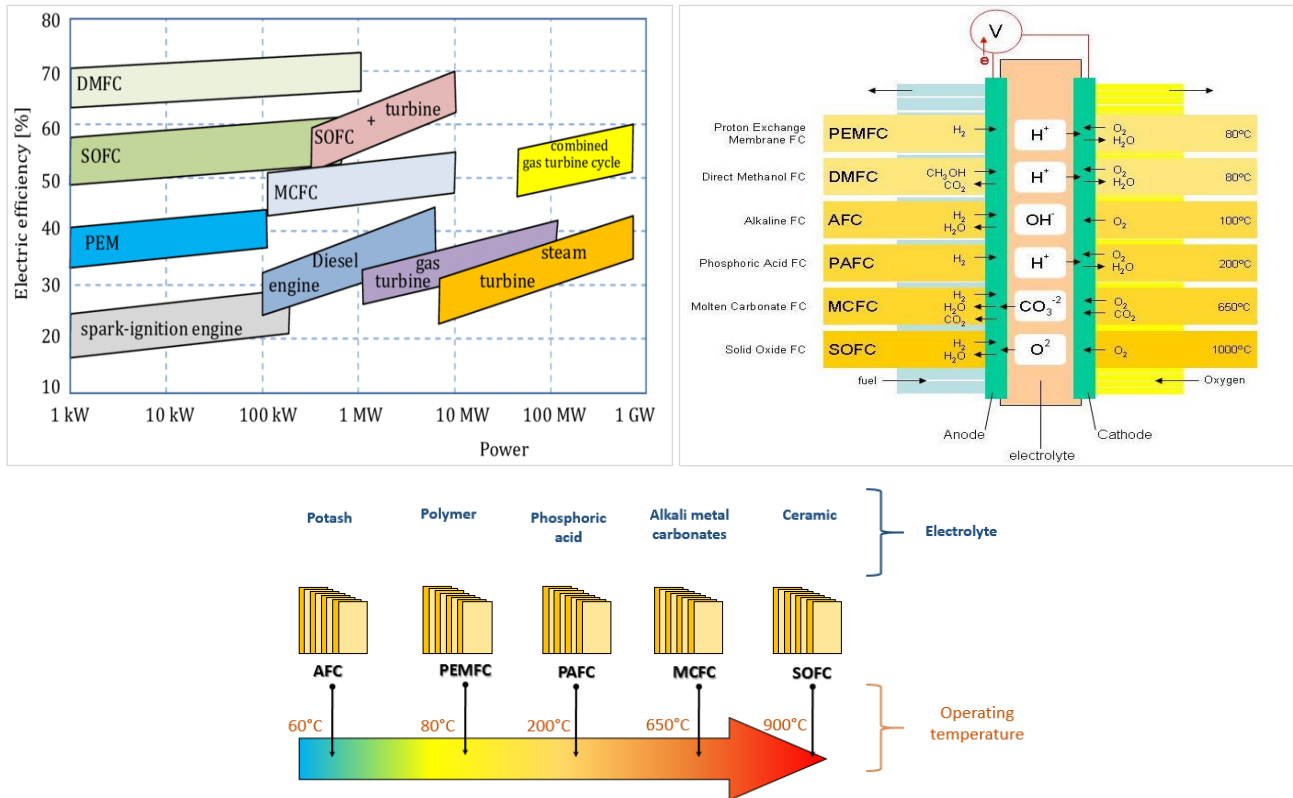

Fig. 49 Comparison of different FCs capabilities of (left) electric efficiency and power production capabilities of FCs (1) (right) inputs and outputs (2) and (bottom) operating temperature (3).

For a more in-depth comparison between all the FCs see annex Fuel Cell Comparison

References:

- (1) [researchgate.net/publication/330566305](https://www.researchgate.net/publication/330566305) The potential of fuel cells as a drive source of maritime transport
- (2) jobsinfuelcells.com/fctypes.htm
- (3) h2sys.fr/en/technologies-2/fuel-cell-systems

7.3. Operating conditions

Pressure

PEM's usually operate optimally between pressures of 1 - 3 atm.

Temperature.

For each fuel cell design, there is an optimal temperature. A fuel cell generates heat as a by-product of the electrochemical reaction, and this heat must be controlled to maintain the desired temperature. PEM's usually operate optimally between 20 - 100 C.

Humidity of reactants

In PEM fuel cell, there is an increased performance (increased power) with high % of humidity of the reactants (Fig. 50). This humidity increases performance because of increased ionic conductivity of the membrane.

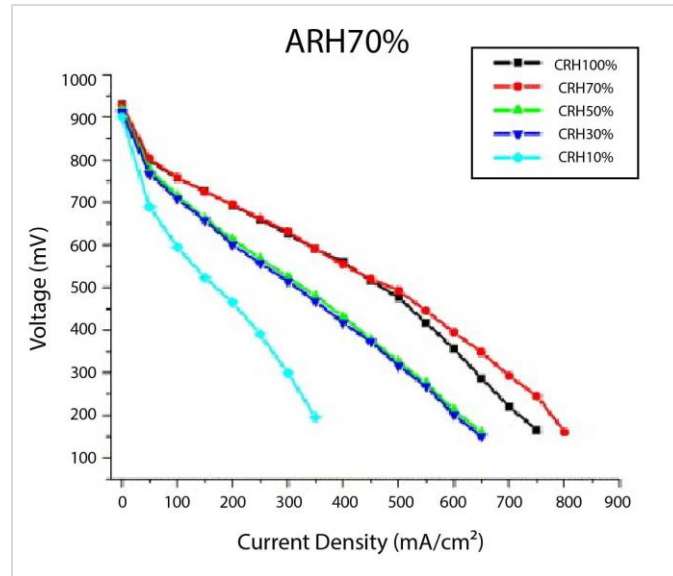

Fig. 50 Polarization curves as function of feed gas humidity in a PEM fuel cell (1).

References:

- (1) L.A.M. Riascos, M.G. Simoes, Paulo, Eigi Miyagi, Mello Moraes. Controlling PEM Fuel Cells Applying a Constant Humidity Technique. *Electrochimica Acta*, Jan 2008.

Mass balance and Flow in/out

The flow rate of the reactants must be equal to, or greater than, the rate at which those reactants are consumed within the cell. Even in a system that uses “atmospheric pressure”, a pressure slightly above atmospheric is needed to push the gasses through the flow fields and force the liquid water out. The additional pressure required is 0.1 to 2.0 psi (0.7 to 13.8 kPa) above atmospheric.

8. HFC Vehicles

8.1. General considerations

Charging of vehicles with electric batteries takes currently a few hours. It's to be expected that as technology advances this could be significantly reduced. Refueling of hydrogen however takes only a few minutes. This difference can be important for vehicles that are operated from extended periods of time and where being stopped is an inefficiency (e.g. self-driving trucks, buses).

Currently one of the main disadvantages of HFC vehicles is the durability of the FC itself, which is only about 120 000 km.

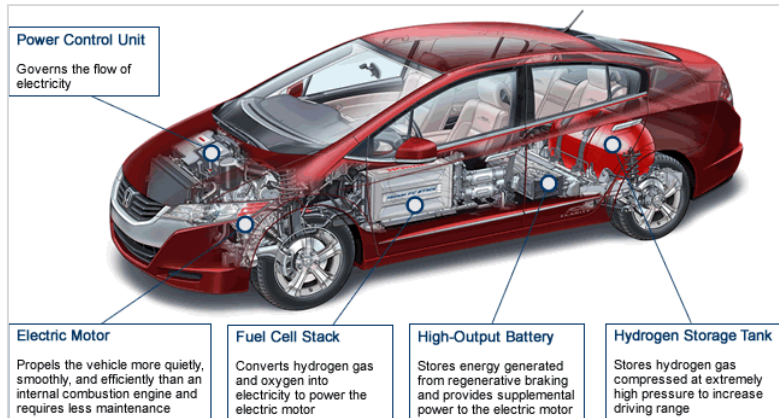

Fig. 51 Main components of a HFC automobile's drive system (2).

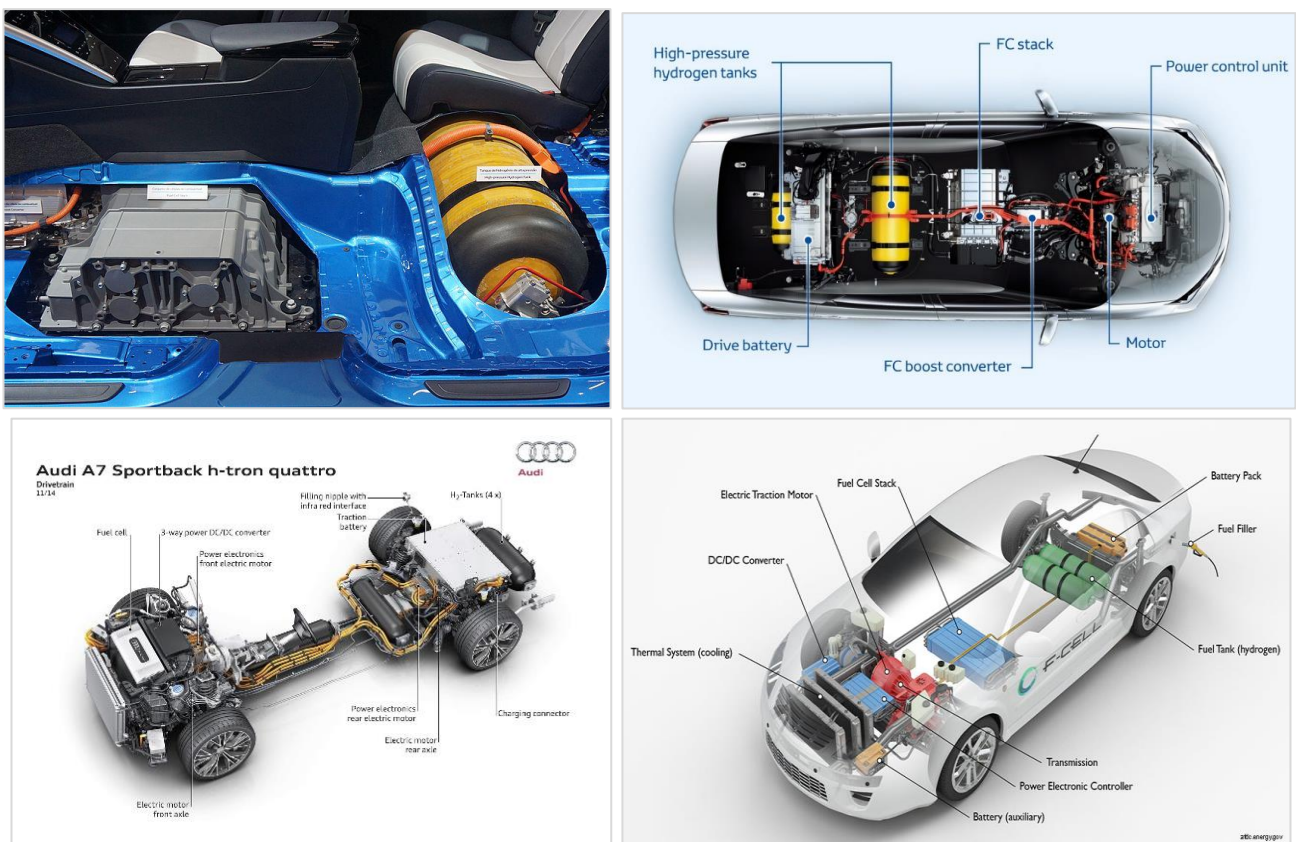

Fig. 52 Toyota Mirai fuel cell stack and hydrogen tank. (1) Toyota Mirai top view hydrogen system. Audi A7 hydrogen system.

References:

- (1) [commons.wikimedia.org/wiki/File:Toyota Mirai fuel cell stack and hydrogen tank SAO 2016 90 32.jpg](https://commons.wikimedia.org/wiki/File:Toyota_Mirai_fuel_cell_stack_and_hydrogen_tank_SAO_2016_90_32.jpg)
- (2) fuelconomy.gov/feg/fuelcell.shtml

8.2. Efficiency of vehicles

Whenever a new technology appears, we always compare it to existing ones. We should be prepared when we are asked about how does a HFC vehicle compares to ICE and fully electric ones. A simple calculation is shown below.

Internal Combustion Engine (ICE) cars:

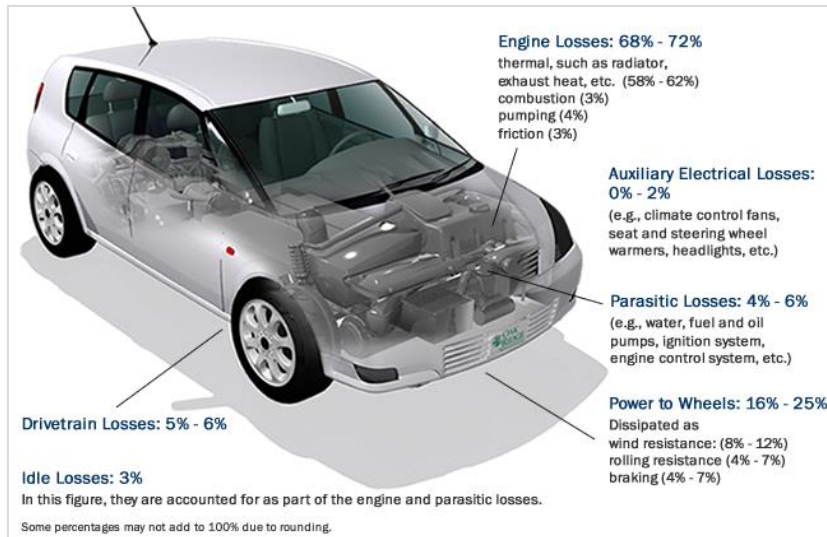

Fig. 53 Energy requirements for Combined City/Highway Driving (3).

$$17\% < \eta_{\text{gasoline cars}} < 21\%$$

Electric cars:

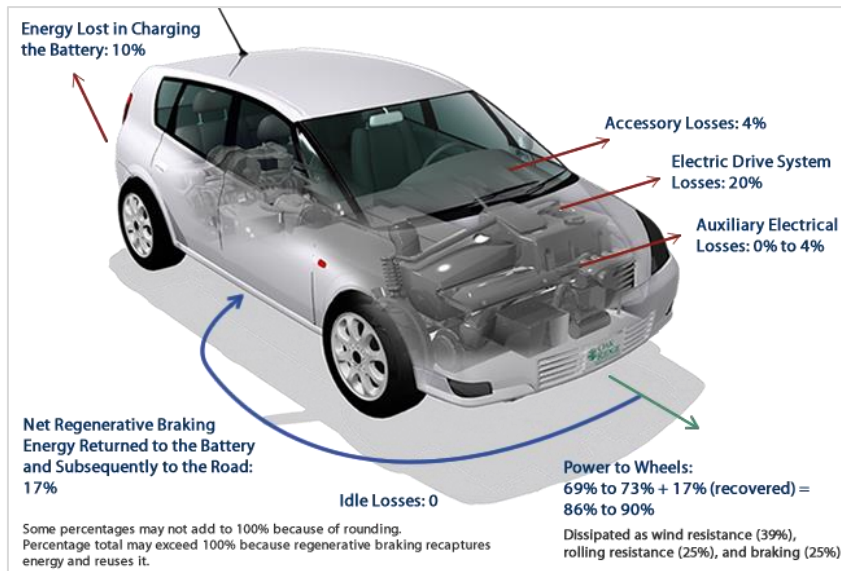

Fig. 54 Energy requirements for combined City/highway driving – All electric vehicles (3)

$$59\% < \eta_{\text{all-electric cars}} < 62\%$$

HFC cars:

$$\eta_{H2 \text{ fuel cell cars, total}} = \eta_{\text{fuel cell}} \cdot \eta_{\text{motor}} \cdot \eta_{\text{transm}}$$

- 30% losses for water make-up and electrolysis: factor 0.70
- 10% losses for compression of hydrogen: factor 0.90
- 10% losses for distribution of gaseous hydrogen: factor 0.90
- 3% losses for hydrogen transfer: factor 0.97
- 50% for conversion to electricity in fuel cells: factor 0.50
- 10% parasitic losses for the hydrogen fuel cell system: factor 0.90
- 10% electric losses in the drive-train between battery and wheels: factor 0.90

Efficiency	%
Fuel Cell	40-80
Transmission	97

$$\% < \eta_{H2 \text{ fuel cell cars, total}} < \%$$

Type of engine	Efficiency (%)
ICE	17 - 21
Electric	78
HFC	

Considering the differences of the supply chain needed for electric vehicles and hydrogen-powered vehicles, the preference seems clear.

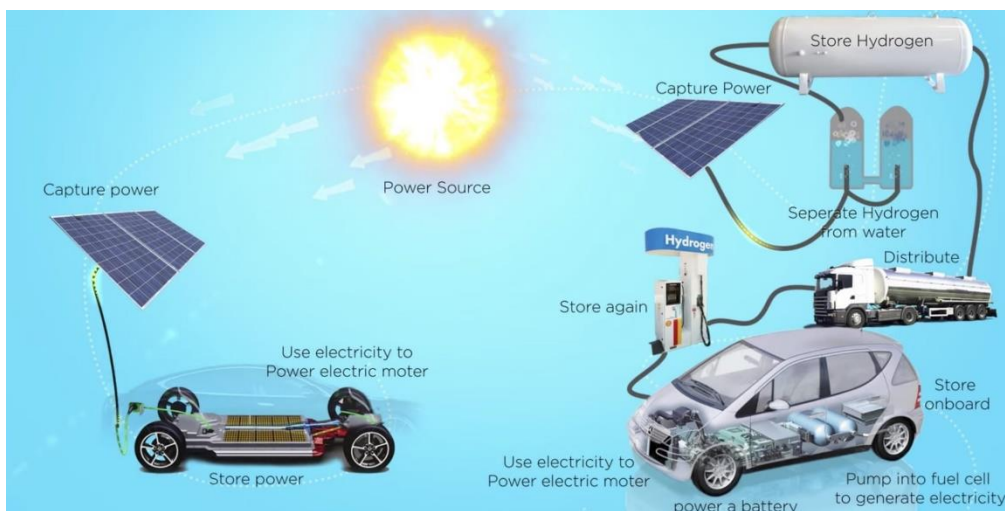

References:

- (1) energy.gov/sites/prod/files/2014/03/f9/thomas_fcev_vs_battery_evs.pdf
- (2) electronics.stackexchange.com/questions/58236/why-does-a-tesla-car-use-an-ac-motor-instead-of-a-dc-one
- (3) fueleconomy.gov/feg/atv-ev.shtml
- (4) butane.chem.uiuc.edu/pshapley/Environmental/L11/2.html

9. Life Cycle

Production --> Compression --> Transport --> Use

10. Equipment

Hydrogen equipment:

- Humidificator / Dryer
- Purificator
- Electrolyser
- Fuel cell
- Sensor
- Tank
- Pressure / flow regulator
- Connectors, tubing, valves
- Power supply / batteries.

11. Suppliers

Hydrogen suppliers can be found in the document:

XX – Folder > Document name here.

12. Standards and Certifications

The Technical Committee (TC) 197 of the International Standards Organization is responsible for standardization of Hydrogen Technologies which has the scope of “standardization in the field of systems and devices for the production, storage, transport, measurement and use of hydrogen.” The most relevant of the standards available were pre-selected and shown in **Table 7**.

Table 7 Relevant ISO Standards (1)

ISO Code	Title
ISO 14687:2019	Hydrogen fuel quality — Product specification
ISO/TR 15916:2015	Basic considerations for the safety of hydrogen systems
ISO/WD TR 15916	Basic considerations for the safety of hydrogen systems

ISO 16110-1:2007	Hydrogen generators using fuel processing technologies — Part 1: Safety
ISO 16110-2:2010	Hydrogen generators using fuel processing technologies — Part 2: Test methods for performance
ISO 16111:2018	Transportable gas storage devices — hydrogen absorbed in reversible metal hydride
ISO 17268	Gaseous hydrogen land vehicle refuelling connection devi
ISO 17268:2012	Gaseous hydrogen land vehicle refuelling connection devices
ISO 19881:2018	Gaseous hydrogen — Land vehicle fuel containers
ISO 19882:2018	Gaseous hydrogen — Thermally activated pressure relief devices for compressed hydrogen vehicle fuel containers
ISO 22734:2019	Hydrogen generators using water electrolysis — Industrial, commercial, and residential applications
ISO 26142:2010	Hydrogen detection apparatus — Stationary applications

Other organizations also provide recommendations or national standards such as the National Fire Protection Association (NFPA), Asia Industrial Gases Association (AIGA), American Institute of Aeronautics and Astronautics (AIAA) and the American National Standards Institute (ANSI).

More Standards and Design Guidelines can be found on the document:

01 - Standards and Regulations > H₂ Design and Handling Standards and Guidelines (*work in progress*).

References

- (1) [ISO Standards for Hydrogen technologies](#)

13. Useful Links

1. allesoverwaterstof.nl
2. opwegmetwaterstof.nl
3. everyspec.com
4. hydrogeneurope.eu
5. h2.live/en/h2mobility
6. fch.europa.eu
7. goeree-overflakkee.nl/duurzaam-go/waterstof_46733

14. Exercises

14.1. Basic knowledge questionnaire

After you finished reading this document you should be able to answer the following questions:

1. Properties
 - 1.1. What makes hydrogen different than other fuels/energy carriers, for the better and for the worse?

- 1.2. Mention the three relevant densities.
2. Production
 - 2.1. What are the two main ways of hydrogen that account for roughly 95% and 5% of hydrogen production globally? And why is that so?
 - 2.2. What materials or substances is hydrogen extracted from?
 - 2.3. What is the difference between grey, blue and green hydrogen?
 - 2.4. What is the decomposition voltage of water?
3. Purification
4. Storage and transportation
 - 4.1. What are the advantages of liquid hydrogen storage over gaseous? And the opposite?
 - 4.2. In gaseous storage, what pressures is it usually stored at?
 - 4.3. There are 3 main ways of combining temperature and pressure that are used for hydrogen storage. Which are they?
 - 4.4. What temperature range is hydrogen liquid?
 - 4.5. What are the main differences when comparing the compression of hydrogen to other gases?
 - 4.6. Which storage method has the highest storage energy efficiency and why?
 - 4.7. What are the two main ways both gaseous and liquid hydrogen can be transported?
5. Safety
 - 5.1. What is the flammability range of hydrogen in dry air and atmospheric pressure?
6. Applications
 - 6.1. Give 10 examples of applications where hydrogen is used nowadays.
 - 6.2. Give 5 examples of applications where hydrogen can be used in the future.
7. Hydrogen Fuel Cell
 - 7.1. What is the reasoning behind using hydrogen and not batteries for energy storage?
8. What are the current main limitations from a more widespread adoption of hydrogen in applications where it could theoretically be used?

14.2. Calculations

Problem:

- a) Determine how long it would take for hydrogen concentration in a laboratory to rise to an explosive level considering the size of the lab is 6x4x3 m and a leak of pure hydrogen of 500 mL/min, and no ventilation.
- b) What measure is usually taken to minimize that risk?

Analysis:

- a)

The lab has a volume

$$V_{lab} = 72 \text{ m}^3$$

Hydrogen is explosive at concentrations between 4% and 74%. To reach a minimum of 4% we would then need

$$V_{H_2,min} = 0.04 \cdot 72 = 2.9 \text{ m}^3$$

Or 2900 L. With a leak flowing 500 mL/min, that would take

$$\dot{V}_{H_2} = 0.5 \text{ L/min}$$

$$V_{H_2, \min} = 2900 \text{ L}$$

$$\dot{V} = \frac{V}{t}$$

From which we get the time

$$t = 5790 \text{ min}$$

Or 96 h, or 4 days.

b)

Most labs have a requirement of 5 air replacements per hour. For this case this would mean an airflow of 360 m³/h. With this kind of ventilation it would be very difficult for hydrogen to buildup to dangerous levels in these conditions.

Problem:

- a) For that same lab, consider the possibility of a a1) local buildup, or a a2) machine buildup. How likely is that? What preventive measures can be taken to prevent such issue?

Analysis:

a)

The diffusion coefficient of hydrogen in air is

$$D_{H_2, \text{air}} = 0.61 \text{ cm} \cdot \text{m}^2 \cdot \text{s}^{-1}$$

Density of hydrogen and air are, at STP,

$$\rho_{H_2} = 0.085 \text{ kg} \cdot \text{m}^{-3}$$

$$\rho_{\text{air}} = 1.2 \text{ kg} \cdot \text{m}^{-3}$$

Which means that

$$\rho_{\text{air}} \approx 14 \cdot \rho_{H_2}$$

Any hydrogen leaked will rise rapidly. Any air movement due to ventilation will facilitate this diffusion through convection.

For a machine buildup situation the hydrogen may be trapped inside of it, and not escape at a sufficient mass flow, thus the hydrogen concentration going into the explosive range. Not only that but, constant exposure to hydrogen causes hydrogen embrittlement in many materials. This can ultimately render part of the machine inoperative.

Here we can use preventive and combative measures.

Preventive:

- Install a sensor in the most probable places where a buildup could occur, for example, in a place of the machine where ventilation is not possible.
- If the machine can be custom-ordered, inquiry about the possibility of adding vents, possibly active ventilation.

Combative:

15. Annexes

15.1. NFPA Guide

NFPA GUIDE

A GUIDE TO NFPA 704 / NFPA FIRE DIAMOND LABELING

HEALTH HAZARD

4 Very short exposure could cause death or serious residual injury even though prompt medical attention is given.

3 Short exposure could cause serious temporary or residual injury even though prompt medical attention was given.

2 Intense or continued exposure could cause temporary incapacitation or possible residual injury unless prompt medical attention is given.

1 Exposure could cause irritation but only minor residual injury even if no treatment is given.

0 Exposure under fire conditions would offer no hazard beyond that of ordinary combustible materials.

FLAMMABILITY

4 Will rapidly or completely vaporize at normal pressure & temperature, or is readily dispersed in air & will burn readily.

3 Liquids and solids that can be ignited under almost all ambient conditions.

2 Must be moderately heated or exposed to relatively high temperature before ignition can occur.

1 Must be preheated before ignition can occur.

0 Materials that will not burn.

INSTABILITY

4 Readily capable of detonation or of explosive decomposition or reaction at normal temperatures and pressures.

3 Capable of detonation or explosive reaction, but requires a strong initiating source or must be heated under confinement before initiation, or reacts explosively with water.

2 Normally unstable and readily undergoes violent decomposition but does not detonate. Also, may react violently with water or may form potentially explosive mixtures with water.

1 Normally stable, but can become unstable at elevated temperatures and pressures or may react with water with some release of energy, but not violently. Materials that will not burn.

0 Normally stable, even under fire exposure conditions, and are not reactive with water.

SPECIAL HAZARDS

The NFPA 704 Standard defines the following symbols:

OX Oxidizer (e.g., potassium perchlorate, ammonium nitrate, hydrogen peroxide)	W Reacts with water in an unusual or dangerous manner (e.g., cesium, sodium, sulfuric acid)	SA Simple asphyxiant gas. Limited to the following gases: nitrogen, helium, neon, argon, krypton & xenon
---------------------------------------------------------------------------------------	----------------------------------------------------------------------------------------------------	-----------------------------------------------------------------------------------------------------------------

Non-Standard Symbols:

COR Corrosive; strong acid or base (e.g. sulfuric acid, potassium hydroxide)	BIO Biological hazard (e.g., smallpox virus)	CYL CRYO Cryogenic (e.g. liquid nitrogen)
☢ Radioactive (e.g., plutonium, uranium)	POI Poisonous (e.g. Strychnine)	

Alternative PPE symbols (not a part of NFPA system)
* There are more PPE symbols than what is shown.

Creative Safety Supply | phone: 1-866-777-1360 | fax: 330-777-8818
www.creativesafetysupply.com | email: info@creativesafetysupply.com

15.2. Properties of commonly used H₂ purification processes

Process	Principle	Typical feed gas	Hydrogen output (%)		Scale of use	Comments
			Purity	Recovery		
Cryogenic Separation	Partial condensation of gas mixtures at low temperatures.	Petrochemical and refinery off-gases.	90–98	95	Large scale	Prepurification step necessary to remove CO ₂ , H ₂ S and water.
Polymer Membrane Diffusion	Differential rate of diffusion of gases through a permeable membrane.	Refinery off-gases and ammonia purge gas.	92–98	>85	Small to large	He, CO ₂ and H ₂ O may also permeate the membrane.
Metal Hydride Separation	Reversible reaction of hydrogen with metals to form hydrides.	Ammonia purge gas.	99	75–95	Small to medium	Hydrogen absorption poisoned by O ₂ , N ₂ , CO and S.
Solid Polymer Electrolyte Cell	Electrolytic passage of hydrogen ions across a solid polymer membrane.	Purification of hydrogen produced by thermochemical cycles.	99.8	95	Small	Sulphur-containing compounds poison the electro-catalysts.
Pressure Swing Adsorption	Selective adsorption of impurities from gas stream.	Any hydrogen rich gas.	99.999	70–85	Large	The recovery is relatively low as hydrogen is lost in the purging step.
Catalytic Purification	Removal of oxygen by catalytic reaction with hydrogen.	Hydrogen streams with oxygen impurity.	99.999	Up to 99	Small to large	Usually used to upgrade electrolytic hydrogen. Organics, Pb-, Hg-, Cd- and S-compounds poison the catalyst. H ₂ O produced.
Palladium Membrane Diffusion	Selective diffusion of hydrogen through a palladium alloy membrane.	Any hydrogen containing gas stream.	≥99.9999	Up to 99	Small to medium	Sulphur-containing compounds and unsaturated hydrocarbon impair permeability.

15.3. Characteristics of hydrogen storage technologies

Technology type	High pressure compressed gas vessels	Liquid hydrogen tank	Metal hydride
Development status	Commercially proven	Commercially proven	Quite developed but not yet commercially proven
Energy efficiency (energy to store / stored energy content of H ₂)	About 93%	About 77%	About 88%
Storage gravimetric efficiency (kg H ₂ / kg total (vessel + H ₂) (%)	5 - 10 %	8 - 25 %	2 - 7 %
Volumetric efficiency	20 kg H ₂ / m ³ @ 350 bar	20 - 50 kg H ₂ /m ³ .	Above 100 kg H ₂ / m ³ .
Applicability	Stationary and road vehicles, laboratories, industry.	Mainly space vehicles, industry.	Target for road vehicles.
Safety considerations	Typical pressure vessel precautions, monitoring & good ventilation needed	In addition to precautions for pressure vessels, care needed to avoid condensed air mixed with hydrogen	Relatively safe
Economic considerations	Relatively least capital & operation costs	Very expensive capital and operation costs and liquefaction	More costly than pressure vessels in capital & operating expenses

Reference: Ni, M. (2006). An overview of hydrogen storage technologies. *Energy exploration & exploitation*, 24(3), 197-209.

15.4. Fuel cell comparison

Fuel Cell Type	Common Electrolyte	Operating Temperature	Typical Stack Size	Electrical Efficiency (LHV)	Applications	Advantages	Challenges
Polymer Electrolyte Membrane (PEM)	Perfluorosulfonic acid	<120 °C	<1 kW - 100 kW	60% direct H ₂ ; 40% reformed fuel.	<ul style="list-style-type: none"> Backup power Portable power Distributed generation Transportation Specialty vehicles 	<ul style="list-style-type: none"> Solid electrolyte reduces corrosion and electrolyte management problems Low temperature Quick start-up and load following 	<ul style="list-style-type: none"> Expensive catalysts Sensitive to fuel impurities
Alkaline (AFC)	Aqueous potassium hydroxide soaked in a porous matrix, or alkaline polymer membrane	<100 °C	1 - 100 kW	60%	<ul style="list-style-type: none"> Military space Backup power Transportation 	<ul style="list-style-type: none"> Wider range of stable materials allows lower cost components Low temperature Quick start-up 	<ul style="list-style-type: none"> Sensitive to CO₂ in fuel and air Electrolyte management (aqueous) Electrolyte conductivity (polymer)
Phosphoric Acid (PAFC)	Phosphoric acid soaked in a porous matrix or imbibed in a polymer membrane	150 - 200 °C	5 - 400 kW, 100 kW module (liquid PAFC) <10 kW (polymer membrane)	40%	<ul style="list-style-type: none"> Distributed generation 	<ul style="list-style-type: none"> Suitable for CHP Increased tolerance to fuel impurities 	<ul style="list-style-type: none"> Expensive catalysts Long start-up time Sulfur sensitivity
Molten Carbonate (MCFC)	Molten lithium, sodium, and/or potassium carbonates, soaked in a porous matrix	600 - 700 °C	300 kW - 3 MW, 300 kW module	50%	<ul style="list-style-type: none"> Electric utility Distributed generation 	<ul style="list-style-type: none"> High efficiency Fuel flexibility Suitable for CHP Hybrid/gas turbine cycle 	<ul style="list-style-type: none"> High temperature corrosion and breakdown of cell components Long start-up time Low power density
Solid Oxide (SOFC)	Yttria stabilized zirconia	500 - 1000 °C	1 kW - 2 MW	60%	<ul style="list-style-type: none"> Auxiliary power Electric utility Distributed generation 	<ul style="list-style-type: none"> High efficiency Fuel flexibility Solid electrolyte Suitable for CHP Hybrid/gas turbine cycle 	<ul style="list-style-type: none"> High temperature corrosion and breakdown of cell components Long start-up time Limited number of shutdowns

Reference: <https://www.energy.gov/eere/fuelcells/comparison-fuel-cell-technologies>

15.5. Hydrogen properties (@~NTP).

Name	Value	Unit
Density (STP)	0.0899	kg/m ³
Molecular weight	2.01594	g/mol
Viscosity	8.81 (1/2 air)	μPa·s
Diffusivity (m ² /hr)	1.697	
Electronegativity	2.2	Pauling scale
Specific heat at constant pressure, c_p	14.89	kJ/kg·K
Specific heat ratio, c_p / c_v	1.383	
Enthalpy	4097.7	kJ/kg
Internal energy	2888	kJ/kg
Entropy	64.44	kJ/kg·K
Melting point	14.01	K
Boiling point	20.268	K
Triple point: Temperature	13.8	K
Pressure	7.2	kPa
Critical point: Temperature	33.25	K
Pressure	1.297	kPa
Heat of melting	58.8	kJ/kg
Heat of vaporization	445.6	kJ/kg
Heat of sublimation	379.6	kJ/kg
Vaporization index	8.9	K cm ³ /J
Vaporization rate of LH ₂ pool	4.2 - 8.3	mm/s
Speed of sound of gas (adiabatic)	1294	m/s
Inversion temperature	193	K
Thermal conductivity	0.187 (7x air)	W/m·K
Thermal expansion coefficient	0.0164 (24x water)	
Diffusion coefficient in air (excess of air)	0.8	
Diffusion velocity in air	< 2	cm/s
Buoyant velocity in air	1.2 - 9	(m/s)
Dielectric constant	1.00026	
Compressibility factor, Z	1.0006	
Index of refraction	1.00012	

Heat of combustion (low)	119.93	kJ/g
Heat of combustion (high)	141.86	kJ/g
Limits of flammability in air	4 to 75	vol %
Limits of detonability in air	13 - 70	vol %
Limits of flammability in oxygen	4.1 - 94	vol %
Limits of detonability in oxygen	15 - 90	vol %
Minimum energy for ignition in air	1.7×10^{-5}	J
Auto ignition temperature	858	K
Hot air-jet ignition temperature	943	K
Flame temperature in air	2318	K
Fraction of thermal energy radiated from flame to surroundings	17 - 25	%
Laminar burning velocity in air	2.65 - 3.25	m/s
Deflagration pressure ratio	8.15	
Detonation velocity in air	1.48 - 2.15	km/s
Maximum experimental safe gap in air	0.008	cm
Quenching gap in air	0.64	m
CJ velocity	1968	m/s
CJ detonation pressure ratio	15.6	p_{CJ}/p_0
Energy release	2.82	MJ/kg mixture
Detonation cell size	15	mm
Critical tube diameter	0.2	m
Detonation initiation energy	1.1	g tetryl
Detonation induction distance	Length/diameter ~ 100	
TNT equivalent	26.5	g TNT / g